

A division of Troy Sheet Metal Works, Inc.  
1024 South Vail Avenue, Montebello, CA 90640  
www.troyproducts.com 323 720-4100

Part No: TP-21F1-SC AND AC-21F1-MOL-DS  
Description: Single Cell Partition and Molle Panel

Vehicle: Ford F150  
Model year: 2021



**Troy Products recommends reading through all installation instructions prior to installation to check that all necessary parts have been included. To comply with manufacturer's safety ratings, all OEM self-threading bolts that are removed must be discarded and replaced with unused bolts at manufacturer's torque requirement.**

#### Tools Required

Sockets/Wrenches: 7mm, 13mm,18mm, 5/16, 7/16, 9/16,1/2 ,5/8  
Drivers: 5/32, 1/8, #2 Phillips head, T15, T50  
Misc: 1-1/8" Hole saw, center punch, 1/8" drill bit, 25/64" drill bit

#### Tools Required for Civilian Model

Sockets/Wrenches: 7mm, 13mm,18mm, 5/16, 7/16, 9/16, ½, 5/8  
Drivers: 5/32, 1/8, #2 Phillips head, T15, T50  
Misc: 1-1/8" Hole saw, center punch, 1/8" drill bit, 25/64" drill bit



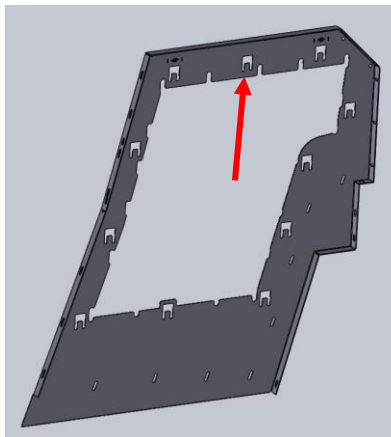





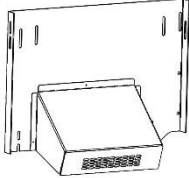
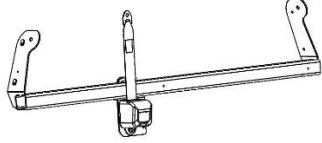
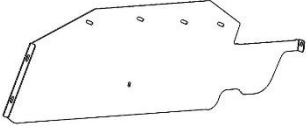

The partition hardware pack is located in box 2 of 3, fixed to the side panel weldment where indicated. The seat mount hardware pack is located in the small PTS box, which is marked with a red sticker.







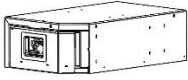

#### Quickstart Guide

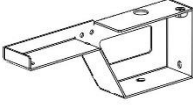
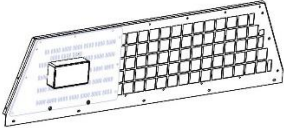



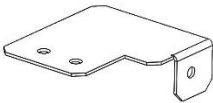
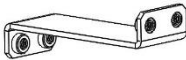

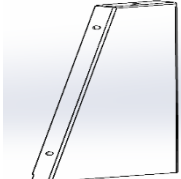
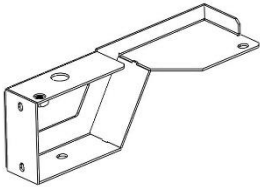
1. Start by attaching the window screen to the seat tube and put it into the vehicle.
2. Put in the combination brackets and electronics tray.
3. Build the single cell. First put in the kick panel and front weldment, then the headliner panel and then the side panel. Make sure to put in the headliner before putting in the side panel.
4. Put the plastic seat in.
5. C-Pillar drill template is used for both side of the vehicle with the DS on the template being visible to the user for the driver side, and the DS not being visible to the user for the passenger side.
6. Electronics pan is removeable so auxiliary components can be added before insertion into the vehicle.
7. For any fasteners going to a slotted hole, ensure a washer is used.
8. Ensure the retractors sensor are plugged back in to prevent error codes.



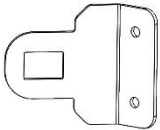

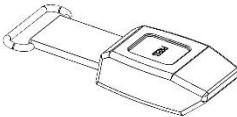

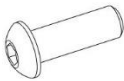
# TP-21F1-SC- BILL OF MATERIALS

PARTS	
<p><b>Part number:</b> TP-21F1-SC-#kp</p> <p><b>Description:</b> KICK PANEL WELDMENT</p> <p><b>QTY: 1</b></p>	
<p><b>Part number:</b> TP-21F1-SC-#tuba</p> <p><b>Description:</b> TOP BAR ASSEMBLY</p> <p><b>QTY: 1</b></p>	
<p><b>Part number:</b> TP-21F1-SC-#spl</p> <p><b>Description:</b> LOWER SIDE PANEL</p> <p><b>QTY: 1</b></p>	
<p><b>Part number:</b> TP-21F1-SC-#tp</p> <p><b>Description:</b> HEADLINER PANEL</p> <p><b>QTY: 1</b></p>	
<p><b>Part number:</b> TP-21F1-SC-#bpb</p> <p><b>Description:</b> B-PILLAR BRACKET</p> <p><b>QTY: 1</b></p>	
<p><b>Part number:</b> TP-21F1-SC-#FB1</p> <p><b>Description:</b> FOOT BRACKET 1</p> <p><b>QTY: 1</b></p>	
<p><b>Part number:</b> TP-21F1-SC-#FB2</p> <p><b>Description:</b> INNER FOOT BRACKET</p> <p><b>QTY: 1</b></p>	
<p><b>Part number:</b> TP-21F1-SC-#lwp</p> <p><b>Description:</b> LOWER WING PANEL</p> <p><b>QTY: 1</b></p>	
<p><b>Part number:</b> PLS-TP-21F1-SC-bp</p> <p><b>Description:</b> PASSENGER WING</p> <p><b>QTY: 1</b></p>	
<p><b>Part number:</b> TP-21F1-SC-#wa</p> <p><b>Description:</b> FRONT PARTITION ASSEMBLY</p> <p><b>QTY: 1</b></p>	
<p><b>Part number:</b> P21F1-31(b)</p> <p><b>Description:</b> 2021 F150 SINGL CELL PLASTIC SEAT</p> <p><b>QTY: 1</b></p>	
<p><b>Part number:</b> TP-21F1-SC-#sgpp</p> <p><b>Description:</b> SIDE GAP PANEL PASSENGER</p> <p><b>QTY: 1</b></p>	
<p><b>Part number:</b> TP-21F1-SC-#ds</p> <p><b>Description:</b> DRIVER SIDE STRAP</p> <p><b>QTY: 1</b></p>	
<p><b>Part number:</b> TP-21F1-SC-#box</p> <p><b>Description:</b> 2021 F150 SINGLE CELL UNDER SEAT BOX</p> <p><b>QTY: 1</b></p>	

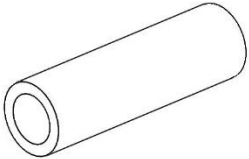
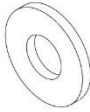

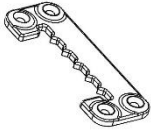
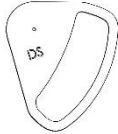
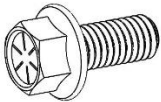
<b>Part number:</b> TP-21F1-SC-#cbpw <b>Description:</b> COMBINATION BRACKET PASSENGER <b>QTY: 1</b> 	<b>Part number:</b> TP-21F1-SC-#rssa <b>Description:</b> REAR SCREEN ASSEMBLY <b>QTY: 1</b> 
<b>Part number:</b> TP-21F1-SC-#ecd <b>Description:</b> EAR COVER WELDMENT DS <b>QTY: 1</b> 	<b>Part number:</b> TP-21F1-SC-#ecp <b>Description:</b> EAR COVER PASSENGER SIDE WELDMENT <b>QTY: 1</b> 
<b>Part number:</b> TP-21F1-SC-#spa <b>Description:</b> SIDE PANEL ASSEMBLY <b>QTY: 1</b> 	<b>Part number:</b> TP-21F1-SC-#b <b>Description:</b> BRACKET <b>QTY: 1</b> 
<b>Part number:</b> PS-21F1-BNCHST-#gpb <b>Description:</b> GAP PANEL BRACKET <b>QTY: 1</b> 	<b>Part number:</b> TP-21F1-SC-#ps <b>Description:</b> Passenger side strap <b>QTY: 1</b> 
<b>Part number:</b> TP-21F1-SC-#edc <b>Description:</b> ELECTRONICS DRAWER COVER <b>QTY: 1</b> 	<b>Part number:</b> TP-21F1-SC-#cbdw <b>Description:</b> COMBINATION BRACKET DRIVER <b>QTY: 1</b> 



### HARDWARE



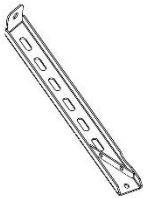

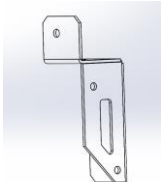
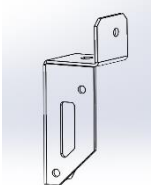

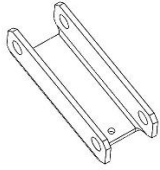

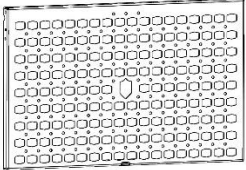
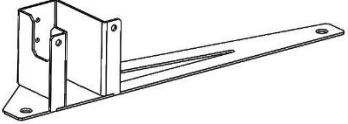
<b>Part number:</b> P003 <b>Description:</b> STORAGE TONGUE <b>QTY: 1</b> 	<b>Part number:</b> DC81 <b>Description:</b> DODGE CHARGER HIP SIDE TONGUE <b>QTY: 1</b> 
<b>Part number:</b> P002 <b>Description:</b> SEAT BELT, BUCKLE ASM <b>QTY: 1</b> 	<b>Part number:</b> 1-FST-06-60825 <b>Description:</b> #1/4-20 x 5/8" BH SOCKET SCREW <b>QTY: 61</b> 
<b>Part number:</b> 1-FST-06-60830 <b>Description:</b> #1/4-20 x 3/4" BH SOCKET SCREW <b>QTY: 31</b> 	<b>Part number:</b> 1-FST-35-31000 <b>Description:</b> #1/4-20 NYLON INSERT LOCKNUT <b>QTY: 49</b> 

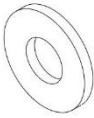
<b>Part number:</b> TP-21F1-SC-#spc <b>Description:</b> 2.5" SPACER <b>QTY: 2</b> 	<b>Part number:</b> 1-FST-50-60800 <b>Description:</b> BLACK FLAT WASHER, 1/4" <b>QTY: 105</b> 
<b>Part number:</b> 1-FST-35-31300 <b>Description:</b> #7/16-20 NYLON INSERT LOCK NU' <b>QTY: 1</b> 	<b>Part number:</b> 1-FST-10-71633 <b>Description:</b> #7/16-20 X 3" HEX HEAD SCREW GRD 8 <b>QTY: 1</b> 
<b>Part number:</b> P004 <b>Description:</b> TOOTHED C-RETAINER <b>QTY: 2</b> 	<b>Part number:</b> PT-21F1-OS-#dt <b>Description:</b> C-PILLAR DRILL TEMPLATE <b>QTY: 1</b> 
<b>Part number:</b> P216 <b>Description:</b> #7/16-20 X 1" FLANGED HEX BOLT <b>QTY: 2</b> 	<b>Part number:</b> 90064A460 <b>Description:</b> EXTERNAL HEX HEAD DRILLING SCREWS FOR METAL <b>QTY: 2</b> 
<b>Part number:</b> P057 <b>Description:</b> #6 X 0.625" PAN HEAD SMS, BLK <b>QTY: 8</b> 	<b>Part number:</b> 1-FST-09-M1015 <b>Description:</b> M10-1.5 X 90mm HEX CAP SCREW 8.8 <b>QTY: 2</b> 

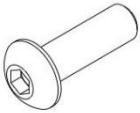
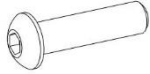
## AC-21F1-MOL-DS - BILL OF MATERIALS (SOLD SEPARATELY)

PARTS	
<b>Part number:</b> AC-21F1-MOL-DS-#gsbw <b>Description:</b> GAS SPRING BRACE WELDMENT <b>QTY: 1</b> 	<b>Part number:</b> AC-21F1-MOL-DS-#gsb2 <b>Description:</b> GAS SPRING BRACKET 2 <b>QTY: 1</b> 
<b>Part number:</b> AC-21F1-MOL-DS-#dpiv <b>Description:</b> DRIVER PIVOT <b>QTY: 1</b> 	<b>Part number:</b> AC-21F1-MOL-DS-#ppiv <b>Description:</b> PASSENGER PIVOT <b>QTY: 1</b> 

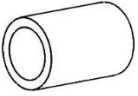
<b>Part number:</b> AC-21F1-MOL-DS-#hng1 <b>Description:</b> HINGE 1 <b>QTY: 2</b>		<b>Part number:</b> AC-21F1-MOL-DS-#hng2 <b>Description:</b> HINGE 2 <b>QTY: 2</b>	
<b>Part number:</b> AC-21F1-MOL-DS-#pan <b>Description:</b> MOLLE PANEL <b>QTY: 1</b>		<b>Part number:</b> AC-21F1-MOL-DS-#fbw <b>Description:</b> FLOOR BRACKET WELDMENT <b>QTY: 1</b>	

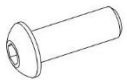
<b>HARDWARE</b>			
<b>Part number:</b> 1-FST-50-60800 <b>Description:</b> BLACK FLAT WASHER, 1/4" <b>QTY: 5</b>		<b>Part number:</b> 1-FST-06-60870 <b>Description:</b> #1/4-20 X 2" BH SOCKET SCREW <b>QTY: 1</b>	
<b>Part number:</b> 1-FST-06-10625 <b>Description:</b> #10-32 x 5/8" BH SOCKET SCREW <b>QTY: 4</b>		<b>Part number:</b> 1-FST-06-60840 <b>Description:</b> #1/4-20 x 1" BH SOCKET SCREW <b>QTY: 2</b>	
<b>Part number:</b> 1-FST-35-31150 <b>Description:</b> #10-32 NYLON INSERT LOCKNUT <b>QTY: 4</b>		<b>Part number:</b> 1-FST-54-94639A <b>Description:</b> .25ID X .5 OD X 5/16" PLASTIC BUSHING <b>QTY: 2</b>	
<b>Part number:</b> 1-HDW-58-03125 <b>Description:</b> GRAY RUBBER BUMPER, 0.3125" HOLE <b>QTY: 2</b>		<b>Part number:</b> 1-FST-35-31000 <b>Description:</b> #1/4-20 NYLON INSERT LOCKNUT <b>QTY: 12</b>	
<b>Part number:</b> RP-21TH-#tub <b>Description:</b> SPACER <b>QTY: 1</b>		<b>Part number:</b> 1-FST-35-30000 <b>Description:</b> #5/16-18 NYLON INSERT LOCK NUT <b>QTY: 2</b>	
<b>Part number:</b> 1-FST-06-60845 <b>Description:</b> #1/4-20 x 1-1/2" BH SOCKET SCREW <b>QTY: 4</b>		<b>Part number:</b> 1-FST-06-60830 <b>Description:</b> #1/4-20 x 3/4" BH SOCKET SCREW <b>QTY: 10</b>	

**Part number:**  
1-HDW-21-3720101

**Description:**  
RUBBER LATCH

**QTY: 1**

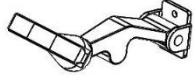

**Part number:**  
1-FST-43-02520

**Description:**  
#1/4-20 RIVET NUT (AVK)

**QTY: 1**

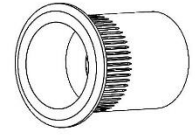

**Part number:**

1-HDW-25-GSP70

**Description:**  
7.5" GAS SPRING, 70#

**QTY: 1**

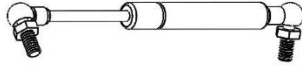

I.) **Rear seat preparation:**

- 1.) Start by removing the rear seat nuts using an 18mm socket and bolts using a 14mm socket four of each. Once these fasteners are removed, remove the retractors from the seats. For the 60 percent seat, there is a latch located by the tiedown strap closest to the driver side door. The pin that must be pushed down for the seat to release is indicated in the image below. Remove the seat belts mounting point from the seat using a T50 torx bit as shown below.

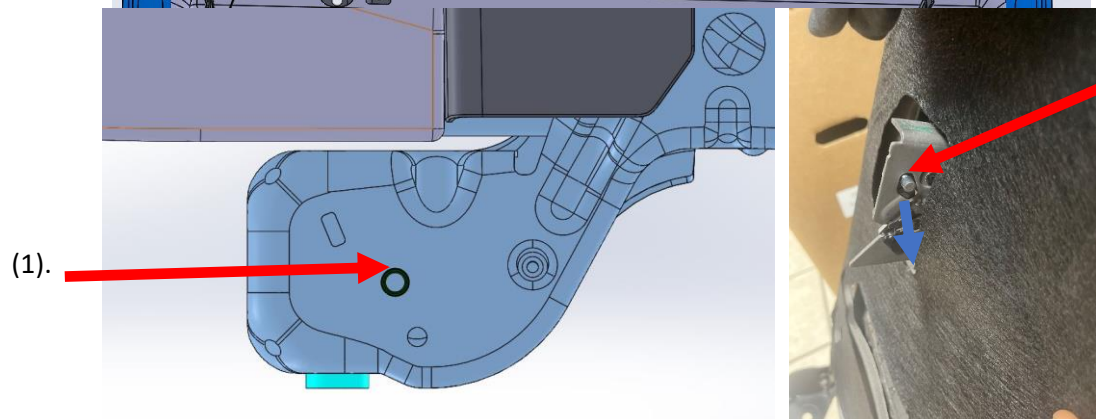
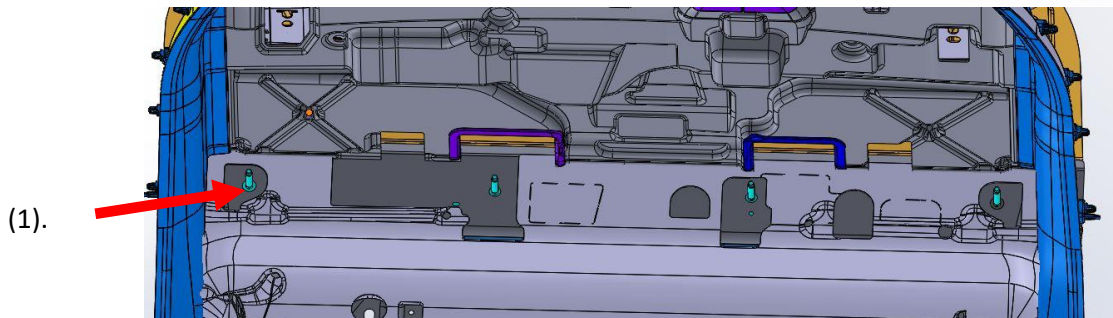
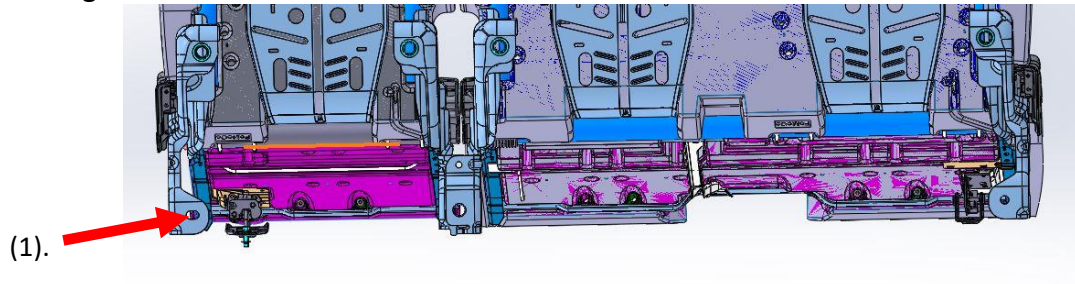

- 2.) Wrap up the rear retractors with the sensors still connected using zip ties and plastic bags so to prevent setting off alarms. Put the retractors behind the cab trim.
- 3.) Then remove the C-pillar trim from both sides of the vehicle. Remove the C-Pillar trim by starting at the top where the pillar trim meets the headliner and start popping out the body clips by getting behind the panel and pulling gently to start.
  - a. Align the drilling template (PT-21F1-OS-#dt) on the trim as shown in the image below and mark the hole with a center punch. **(Ensure on the template you have the DS visible for driver side and the blank face visible for the passenger side.)** Then use a 1/8" drill bit for a pilot hole then use a 1-1/8" hole saw.

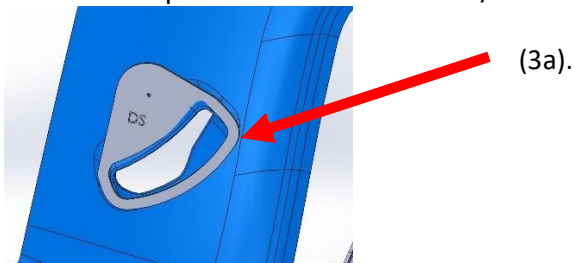

- 4.) Put the C-Pillar trim back into the vehicle with the belts and tongues tucked behind the panel.
- 5.) Remove the upper B-pillar trim on the passenger side of the vehicle and remove the OEM handle using a 7mm socket for the two bolts. Wait to put the b-pillar trim back on for a later step.

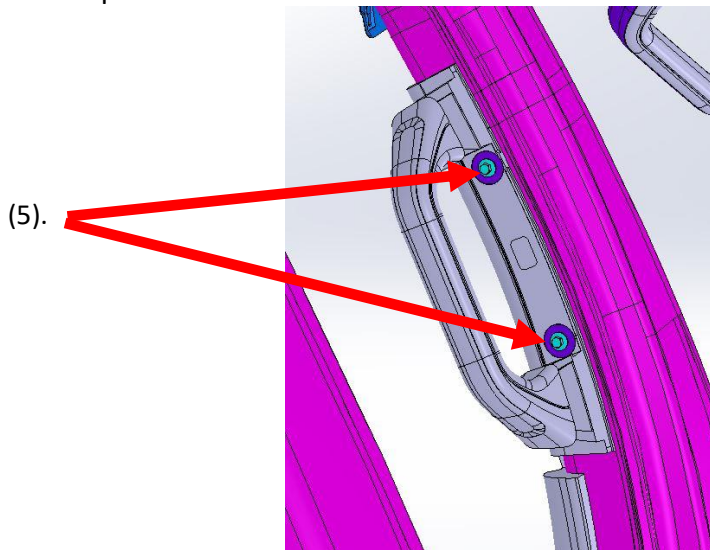

- 6.) Remove the OEM plastic surrounding the rear foot brackets on the front passenger seat. The driver side plastic is only surrounding the rear bracket on that side while the passenger side plastic goes along the side of the car up to the front foot bracket for the front passenger seat using a T15 torx bit for the smaller screws holding the plastics to the seat. Loosen the rear bolts of the front passenger seat using a 14mm socket, leave loose for a later step.

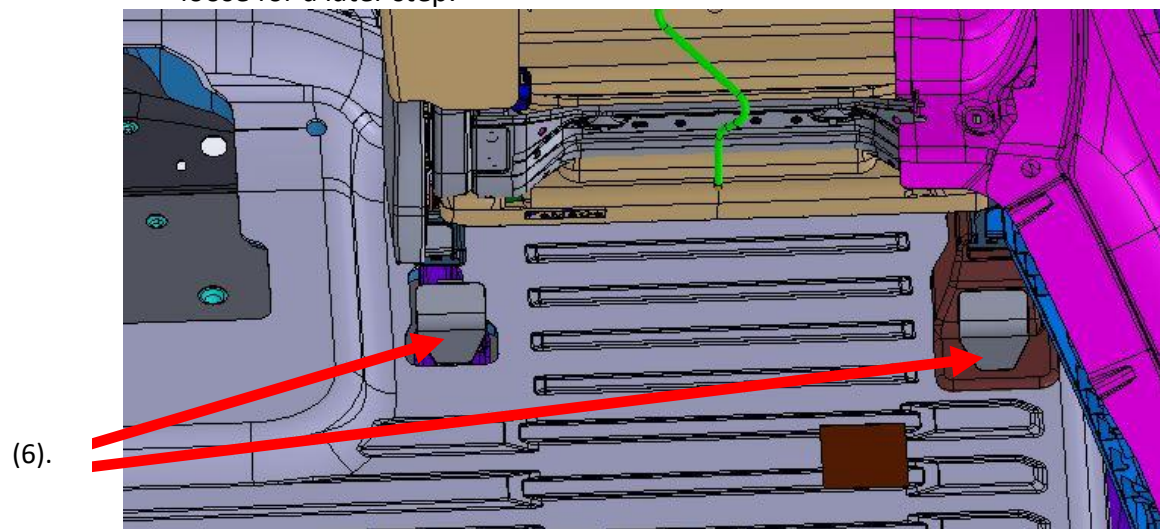

Torx screws are here on plastics

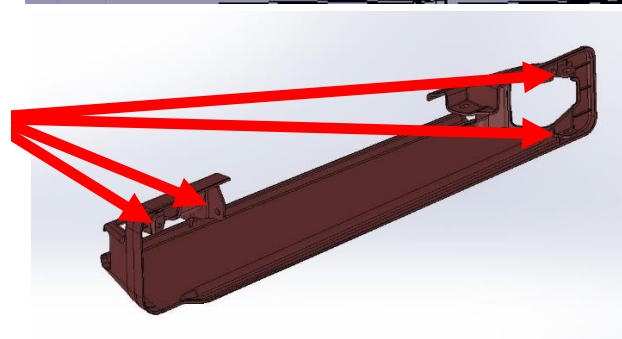

Torx screws are here on plastics

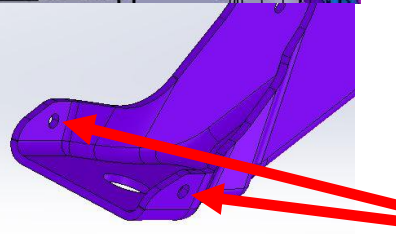

## II.) Install Single cell:

- 7.) Using nine provided 1/4-20 x 0.625" button head screws using a 5/32" allen key or bit and five provided washers attach rear window screen (TP-21F1-SC-#rssa) to seat tube assembly (TP-21F1-SC-#tuba) outside of the vehicle.

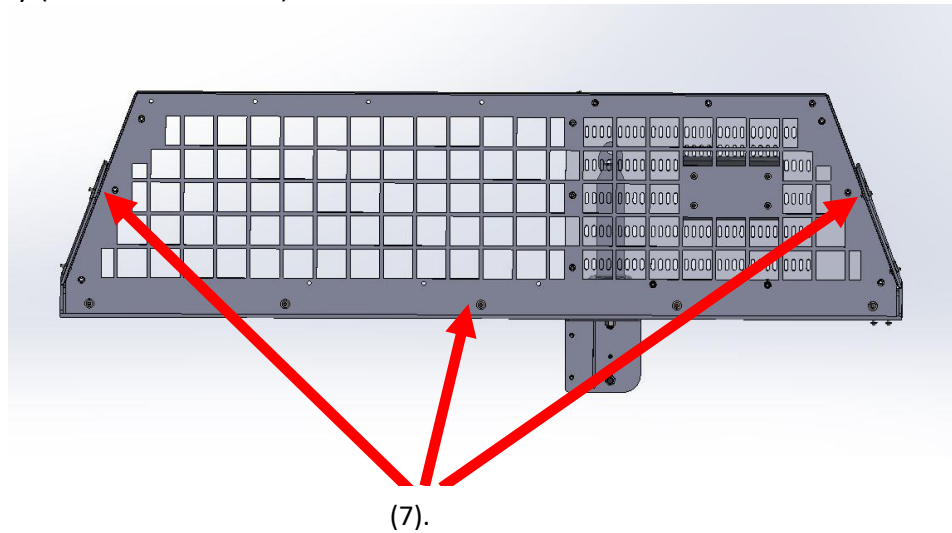

- 8.) Using the holes drilled in the c-pillar from step 3 mount the top bar assembly (#tuba) with the rear screen assembly using 2 provided spacers (TP-21F1-SC-#spc) and 2 provided M10-1.5 x 90mm Hex cap screws using a 15mm socket into the OEM Holes in the C-pillar.

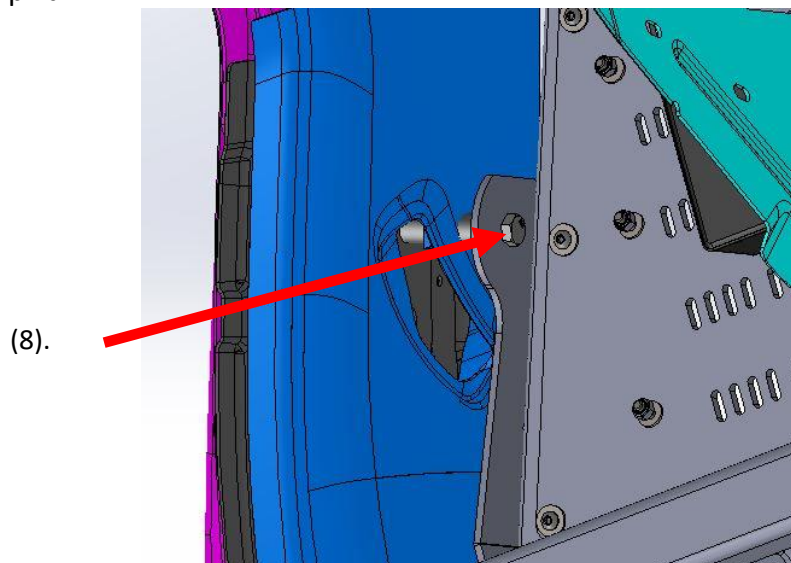

- 9.) Mount the floor bracket driver and passenger side (TP-21F1-SC-#cbdw and TP-21F1-SC-#cbpw) into the floor of the vehicle using the OEM Bolts. Wait to put the OEM nuts onto the rear studs.

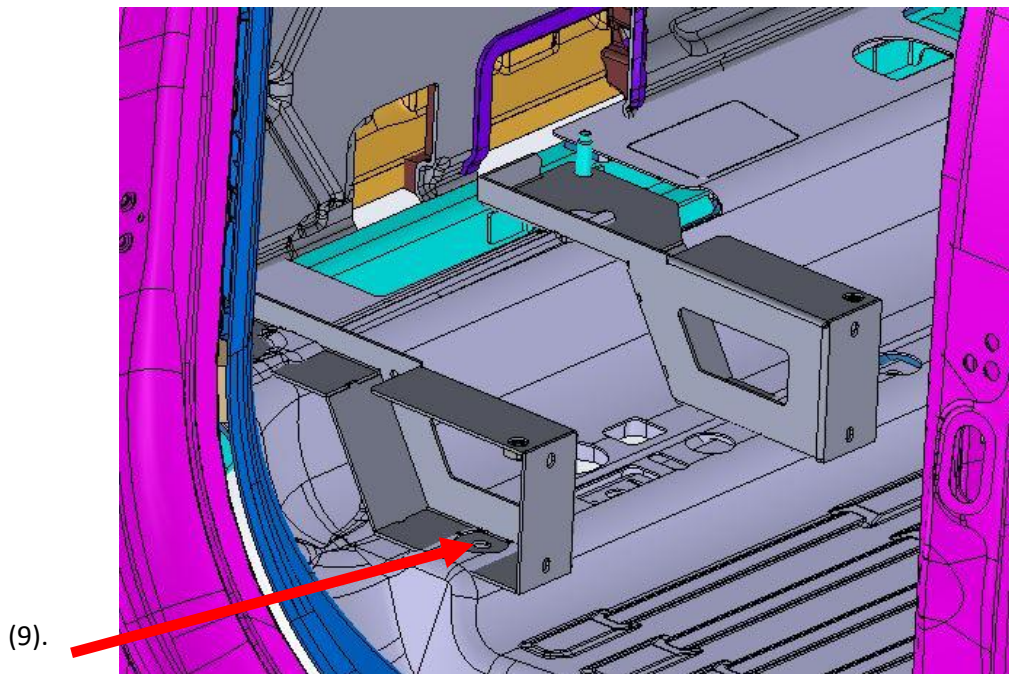

(9).

- 10.) Mount the bottom of passenger side bracket (TP-21F1-#ps) on the same OEM stud closest to the passenger side as in the previous step. Put an OEM nut onto the OEM stud. Place the gap panel brace (TP-21F1-#b) in between the top of #ps and the bottom of the tube of #tuba. Fasten this into place using two provided 1/4-20 x 0.75" button head screws.

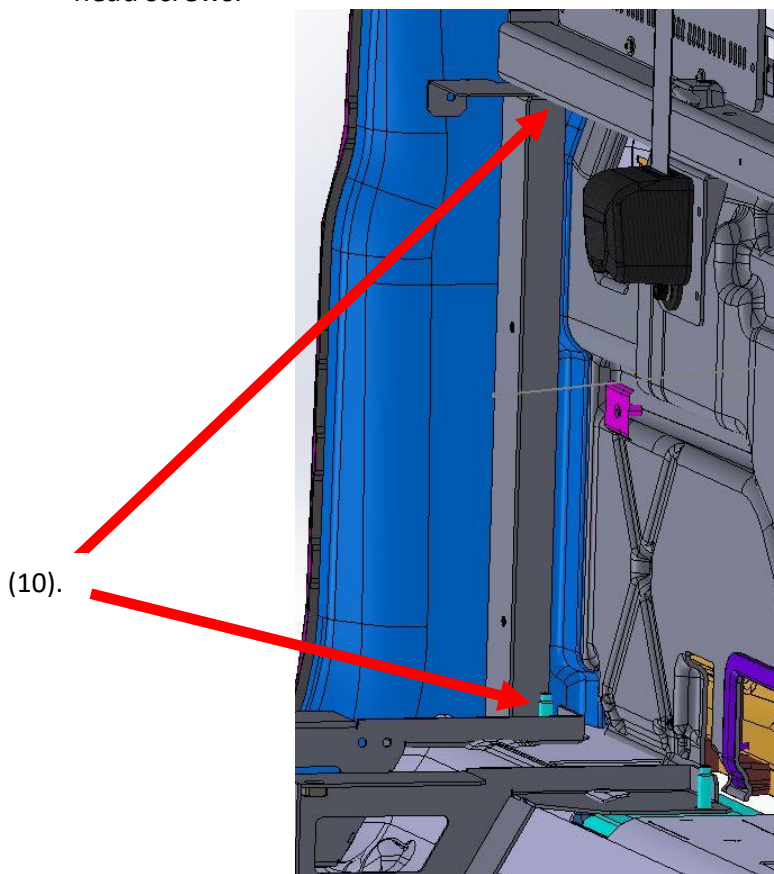

(10).

- 11.) Mount the bottom of driver side bracket from the electronics tray (TP-21F1-#ds) on the OEM seat stud to closest to the right as the previous step. Using an OEM nut put it onto the OEM stud.

(11).

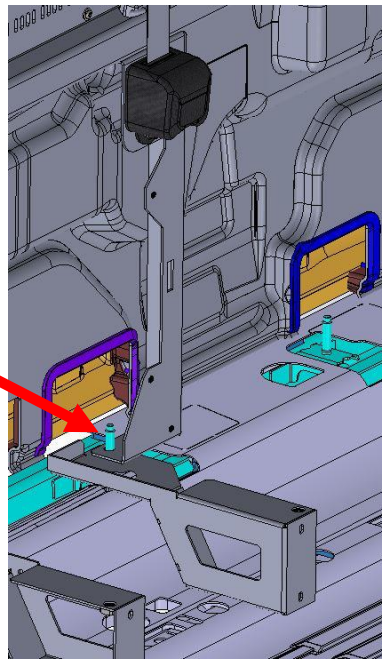

- 12.) Fasten the B-pillar bracket (TP-21F1-SC-#bpb) to the vehicle using the OEM fasteners from the handle located in the B-pillar removed in step 5. Reattach the upper B-pillar trim panel.

(12).

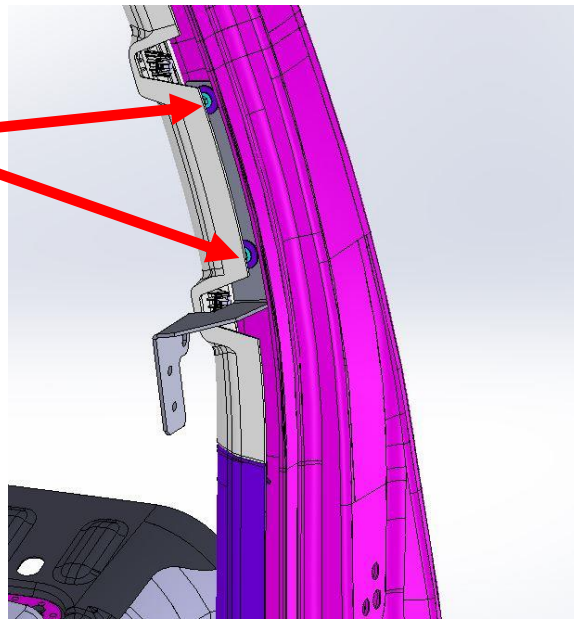

Attaching part number **EM-21F1-ECOVER-2ROW-#ep** and part number **TP-21F1-SC-#edc**.

**EM-21F1-ECOVER-2ROW-#ep**

Attach the electronics panel to the assembly with the following hardware.  
(QTY 5) 1/4-20 x .625" BH socket screw  
(QTY 5) 1/4" Sae Flat Washer, Black 5/8"

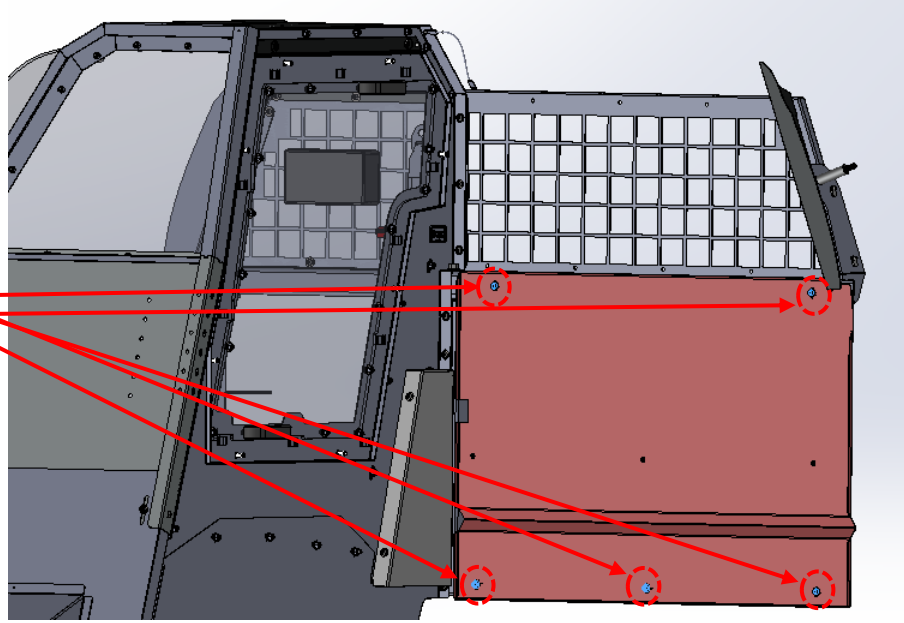

**TP-21F1-SC-#edc**

1. Place the electronics drawer cover on its desired mounting point. Align the plate and insert (QTY 3) 1/4-20 x 0.625" button head socket screw with 1/4-20 flat washers. Photo attached below for reference.

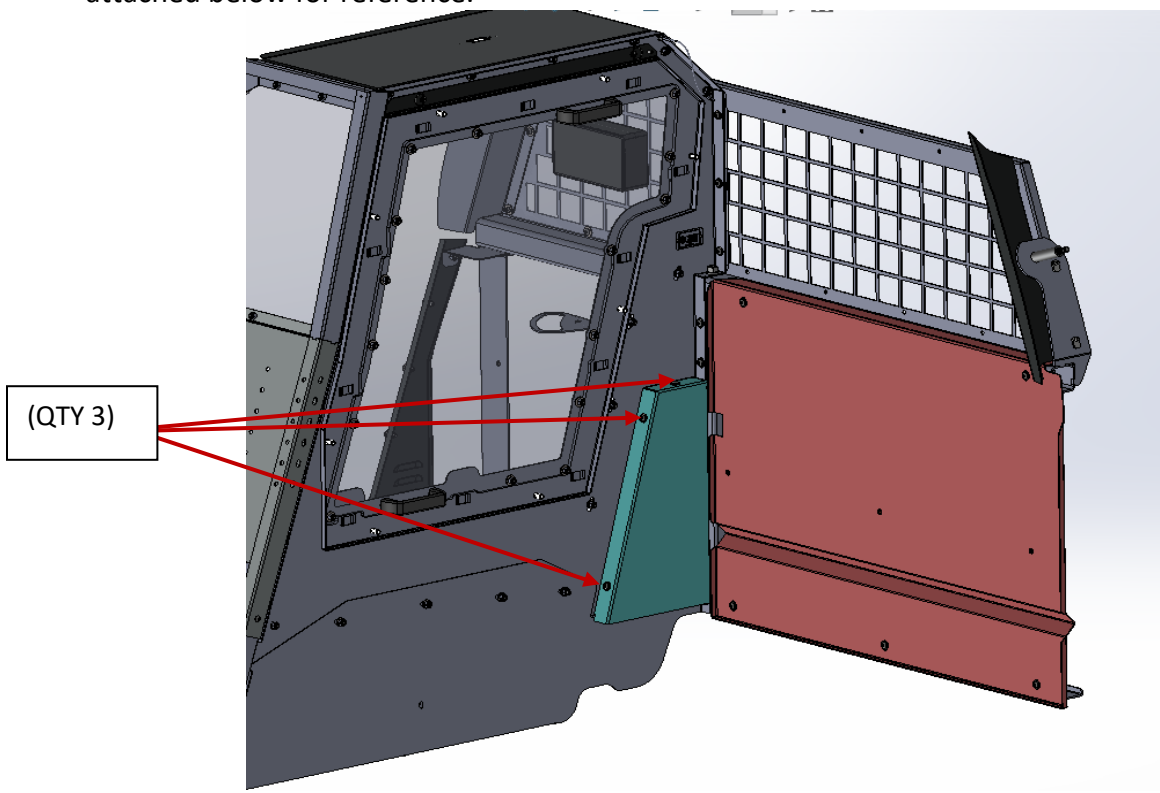

- 13.) Mount under seat storage box (TP-21F1-SC-#box) into the vehicle through the holes shown below on floor brackets using four provided 1/4-20 x 0.625" button head screws and washers.

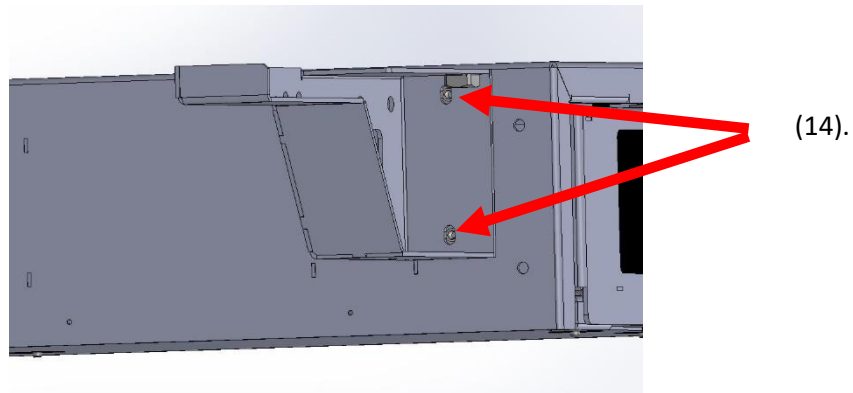

- 14.) Mount the Z-bracket (PS-21F1-BNCHST-#gpb) to the passenger side floor bracket using two provided 1/4-20 x 0.75" button head screws.

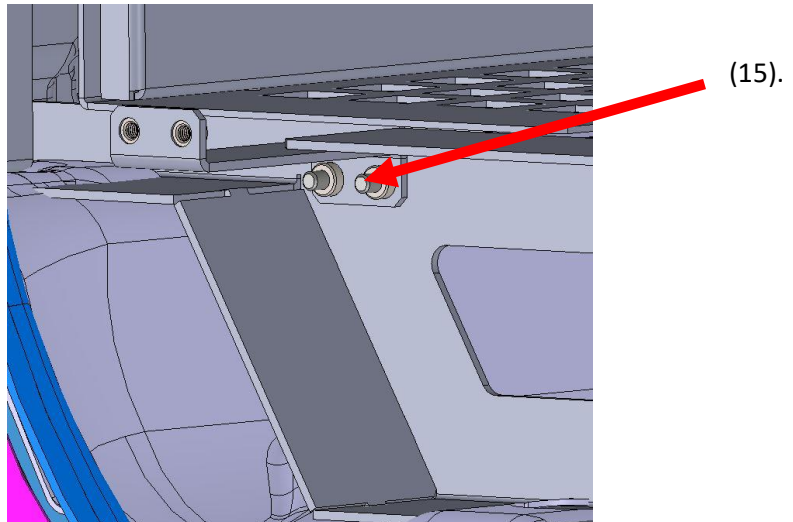

- 15.) **For attaching #sgpp to #box, to remove the drawer of #box to access the pem studs of #sgpp.** Mount the gap panel (TP-21F1-SC-#sgpp) to #box using two provided 1/4-20 nylon lock nuts on the inside of #box, #b with a provided 1/4-20 x 0.625" button head screw, and #gpb using two provided 1/4-20 x 0.75" button head screws and washers.

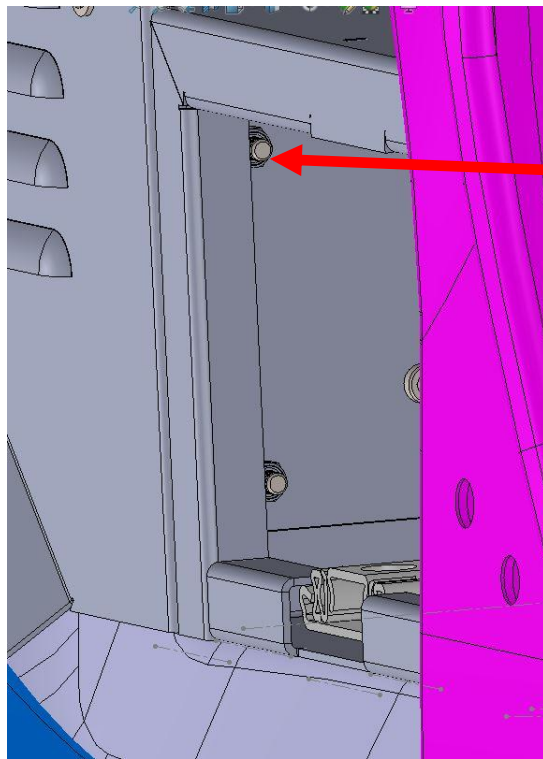
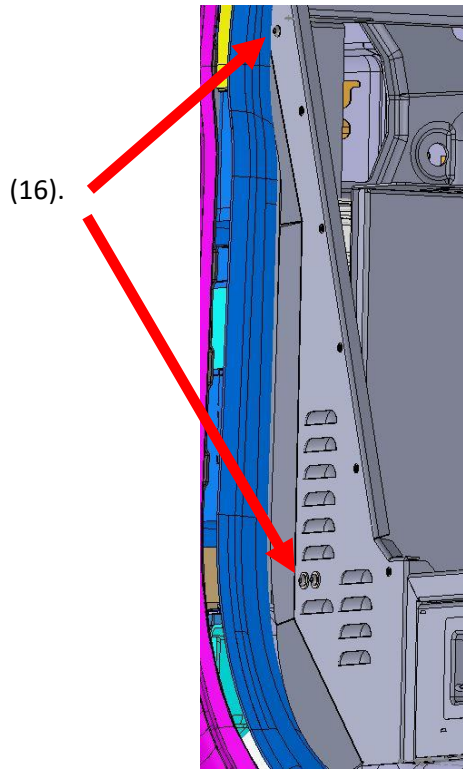

16.) Mount the passenger side foot bracket (TP-21F1-SC-#FB1) towards the passenger side from the front passenger seat. Use an OEM bolt to fasten the foot bracket.

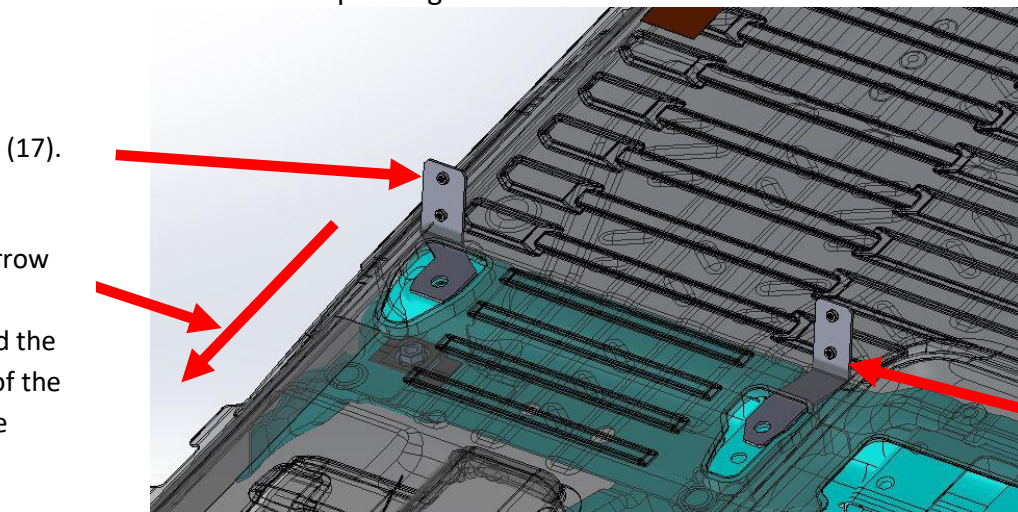

17.) Mount the driver side foot bracket (TP-21F1-SC-#FB2) towards the driver side from the front passenger seat. Use an OEM bolt to fasten the foot bracket.

18.) Mount the kick panel (TP-21F1-SC-#kp) into the vehicle by attaching it to #FB1 and #FB2 and fastening it with four provided 1/4-20 x 0.625" button head screws and washers.

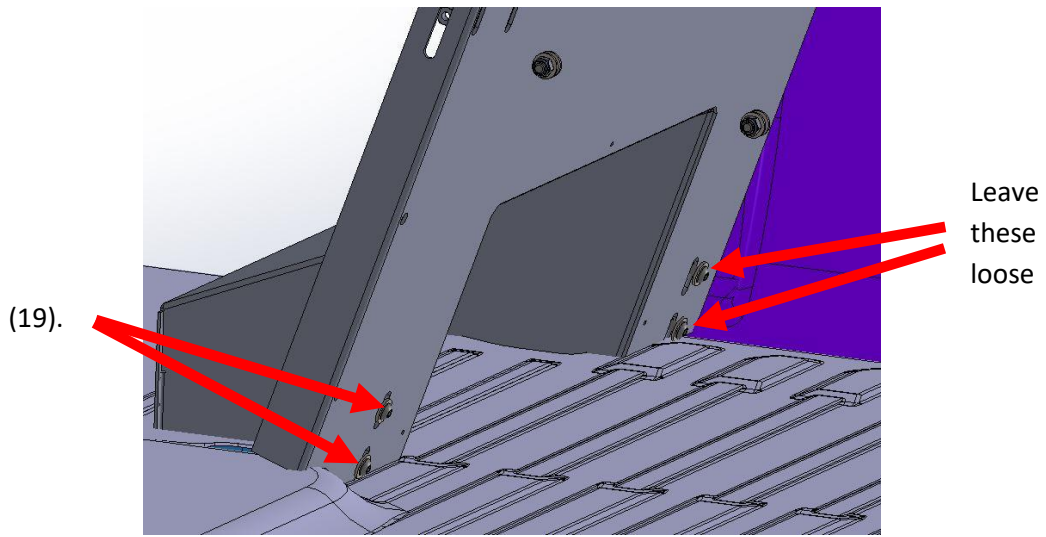

19.) Mount the front partition (TP-21F1-SC-#wa) into the vehicle using five provided 1/4-20 x 0.625" button head screws with washers and nylon lock nuts. You will have to tilt #kp towards the rear of the vehicle to get #wa onto #kp. (Ensure these fasteners go into the inner slots on #kp and the side slots.) **Leave the outer slots on the main face of #kp empty for right now.**

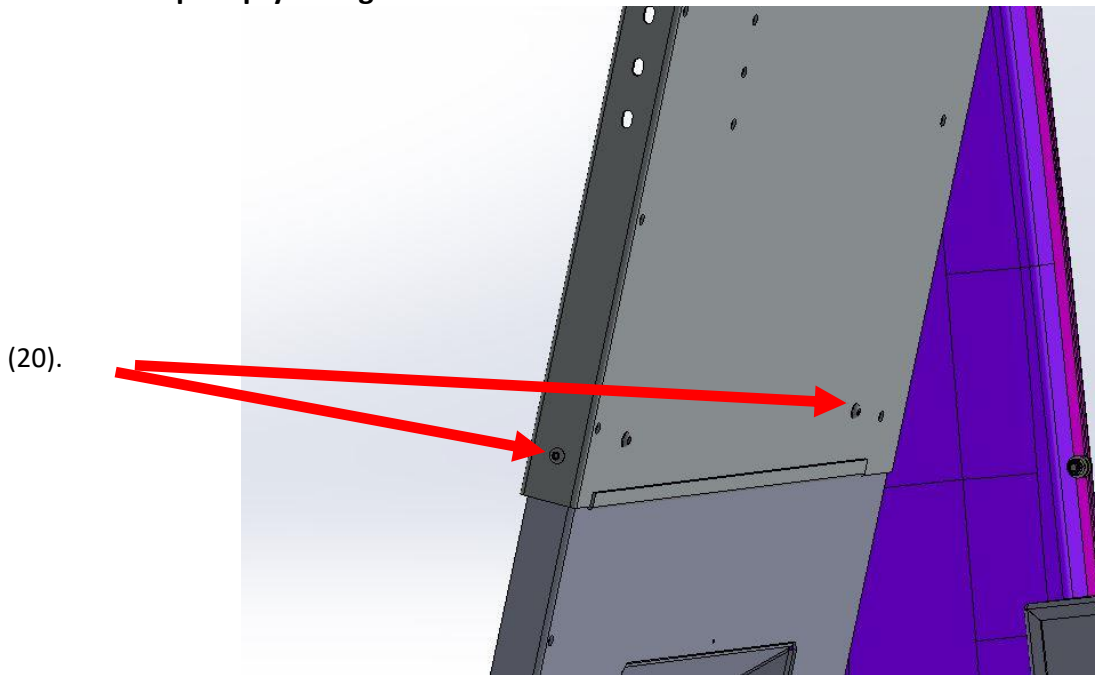

20.) Fasten the headliner panel (TP-21F1-SC-#tp) to #wa using two provided 1/4-20 x 0.625" button head screws with washers and nylon lock nuts and to #rssa using three provided 1/4-20 x 0.75" button head screws with washers. (21).

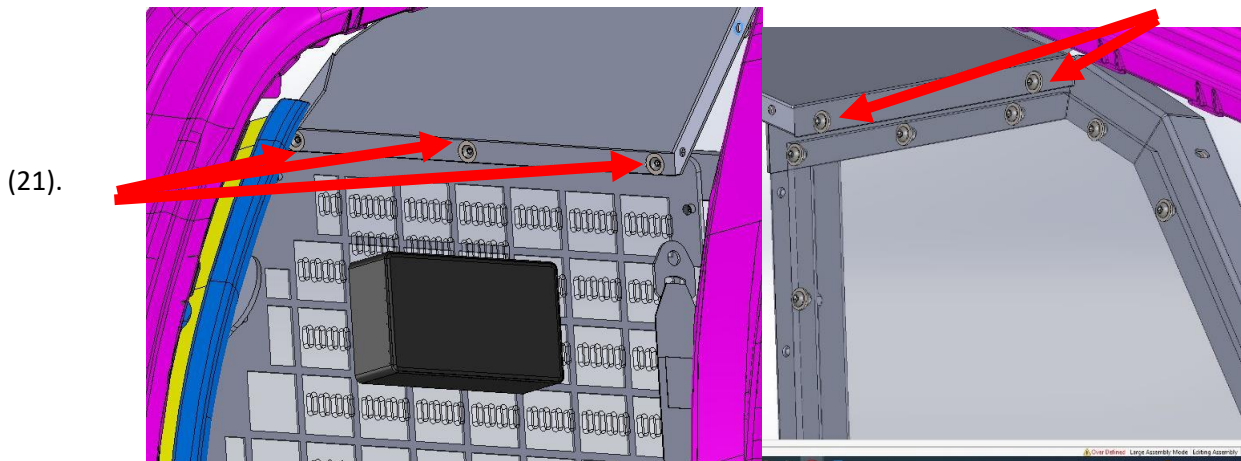

(21).

21.) Fasten plastic upper wing (PLS-TP-21F1-SC-bp) to #wa using three provided 1/4-20 x 0.75" button head screws with washers and nylon lock nuts.

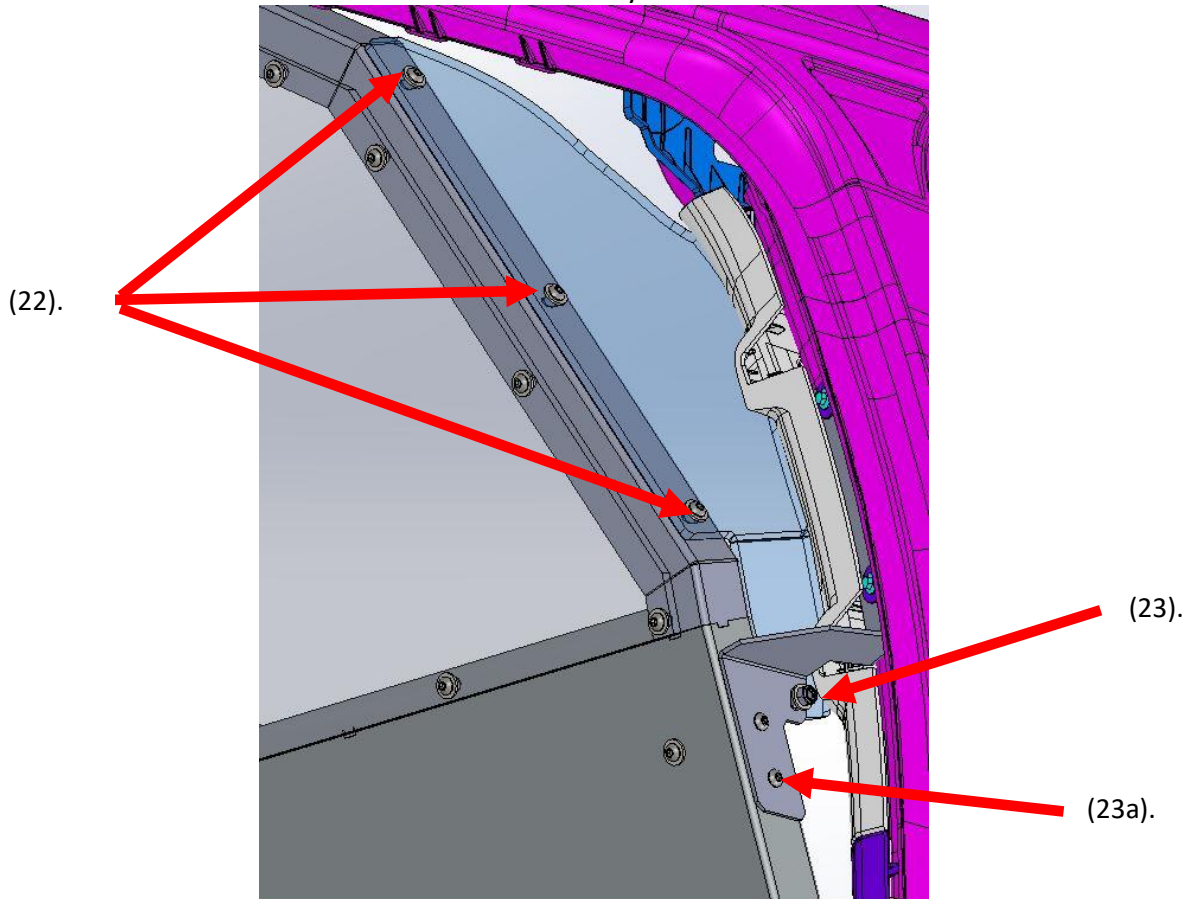

(22).

(23).

(23a).

22.) Fasten #bpb to bp using a provided 1/4-20 x 0.75" button head screw with washers and a nylon lock nut.

a. Fasten #bpb to #wa using two provided 1/4-20 x 0.625" button head screws with washers and nylon lock nuts.

23.) Before installing the side panel assembly (TP-21F1-SC-#spa), remove the two provided Quarter turn Receptacles from #spa that are holding #rfa in place, then remove #rfa from #spa. Fasten #sp to the single cell using nineteen provided 1/4-20 x 0.625" button head screws with washers and fourteen provided nylon locknuts. (5 of these fasteners go into #rssa and #ds, use pem nuts.)

a. Put a provided 7/16-20 x 3" Hex head flange bolt using a 5/8" socket through #spa, the tube of #tuba and #ds and use a provided 7/16-20 Nylon Lock Nut using a 5/8" socket on the #ds side.

(24).  
All  
fasteners  
along this  
edge

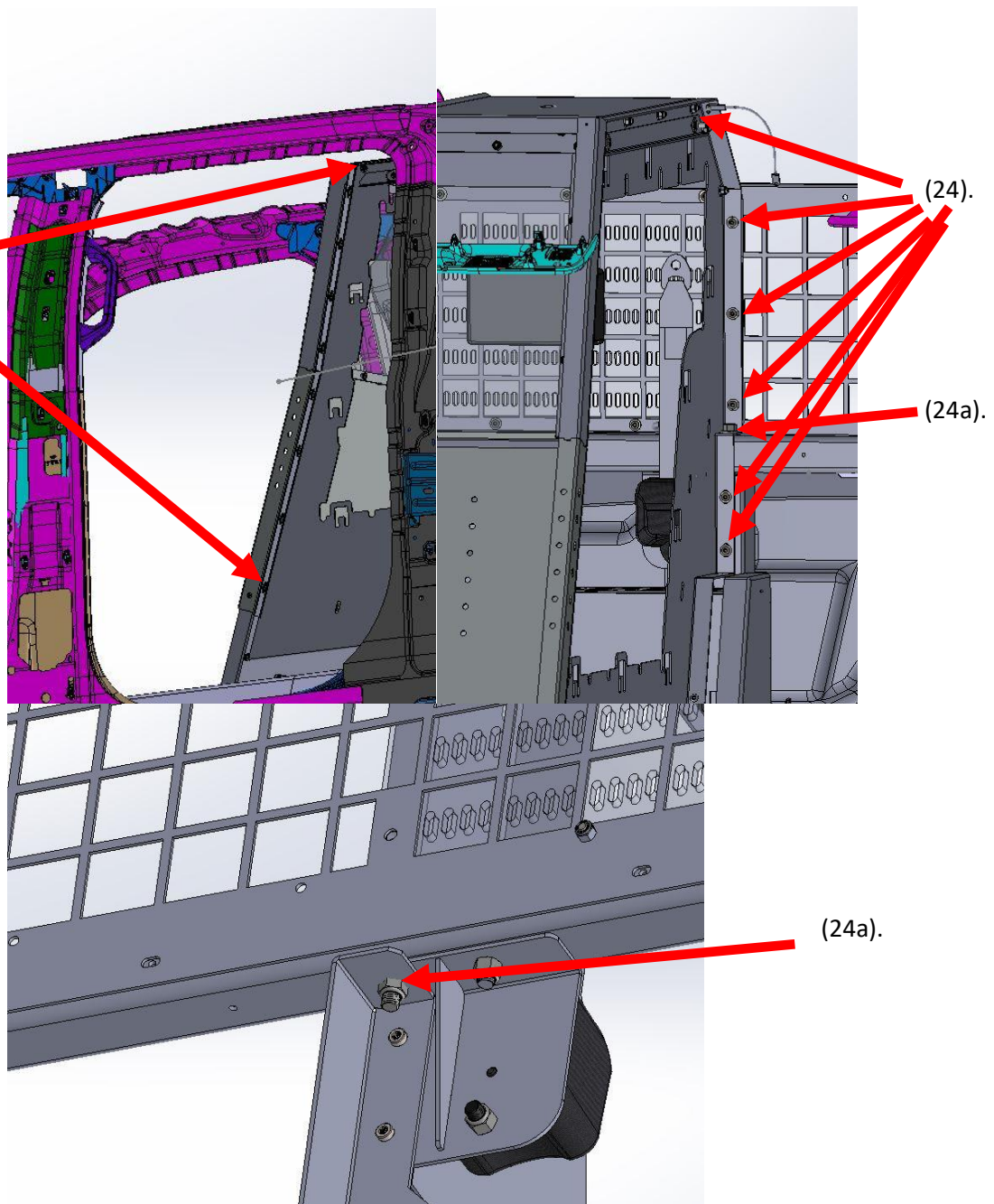

24.) Next, fasten hip side tongue (DC81) using a provided 7/16-20 x 1" Hex head flange bolt to #ps. Ensure the buckle's orientation is the same as shown below. Daisy chain three or four zip ties through the buckle to allow it to be fed through the plastic seat.

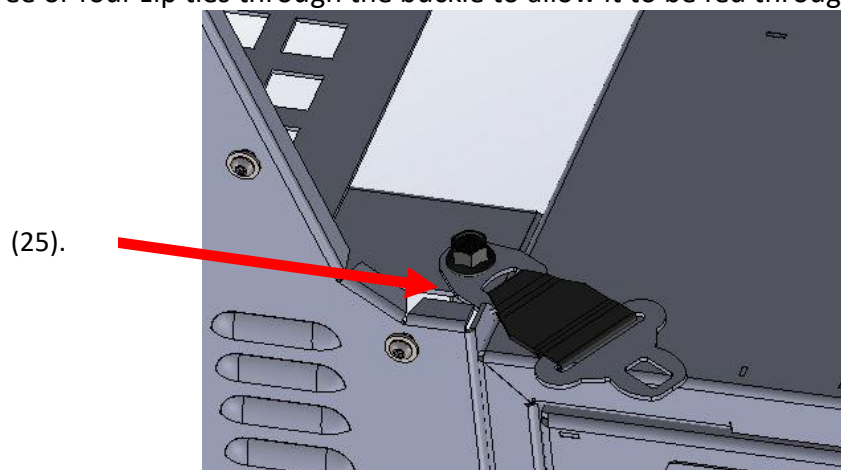

- 25.) Place the plastic seat (P21F1-31(b)) into the vehicle feeding the seat belt from #tuba and DC81 (**use zip ties from previous for easier install**) through their respective slots in the plastic seat. The retractor that is attached to #tuba feeds through a slot in the top of the plastic seat then into the swivel (D-ring) and then into a slot on the driver side of the plastic seat. Fasten the end of the retractor using a provided 7/16-20 x 1" Hex head flange bolt into #ds.

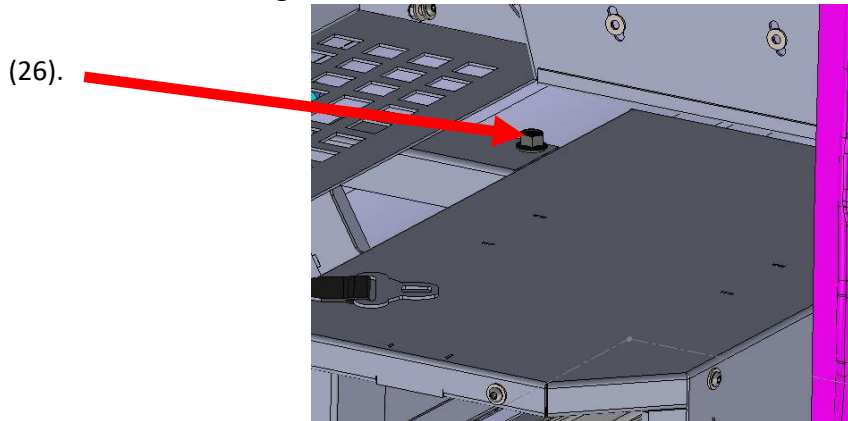

- a. Then, fasten the plastic seat to #sgpp, #box and #spa using five provided 1/4-20 x 0.75" button head screws with washers for #sgpp, three provided 1/4-20 x 0.75" button head screws with washers for #box and only use four provided 1/4-20 x 0.625" button head screws with washers and nylon locknuts into #spa into the holes specified in the image below.

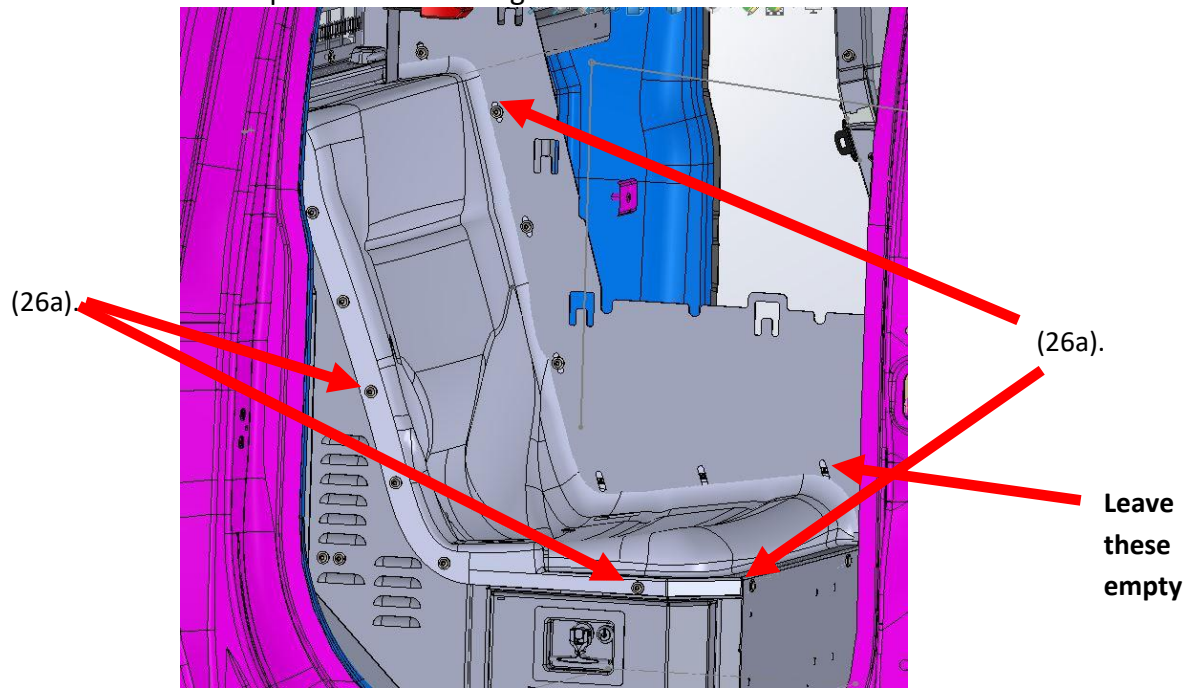

- 26.) With the belts feeding through the slots in the plastic seats attach the two toothed c-retainers using eight provided #6 x 0.625" sheet metal screws using a #2 Phillips head as shown in the image shown below.

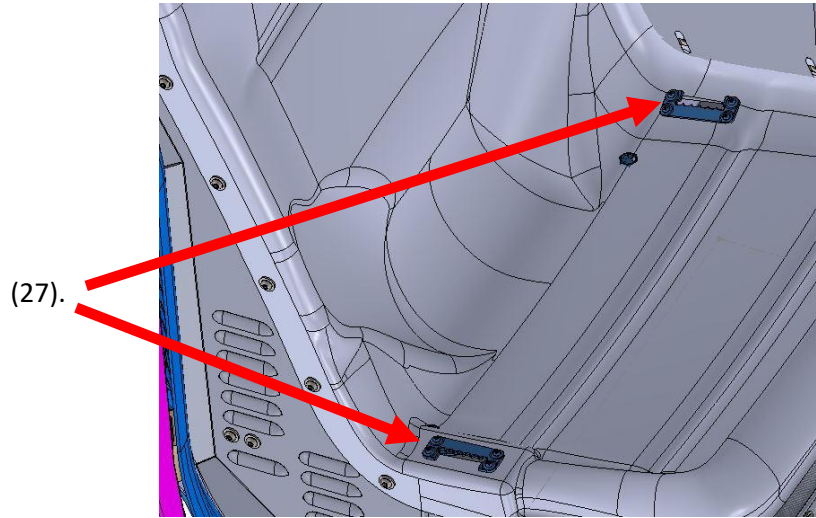

27.) Fasten the lower side panel (TP-21F1-SC-#spl) onto #spa using four provided 1/4-20 x 0.625" button head screws with washers and nylon locknuts, these four screws will also fasten through the plastic seat. Use one provided 1/4-20 x 0.625" button head screw and washer to fasten #spl to #box. Use one provided 1/4-20 x 0.625" button head screw and washer to fasten #spl to #ds. Use two provided 1/4-20 x 0.625" button head screws with washers and nylon locknuts to fasten #spl to #kp.

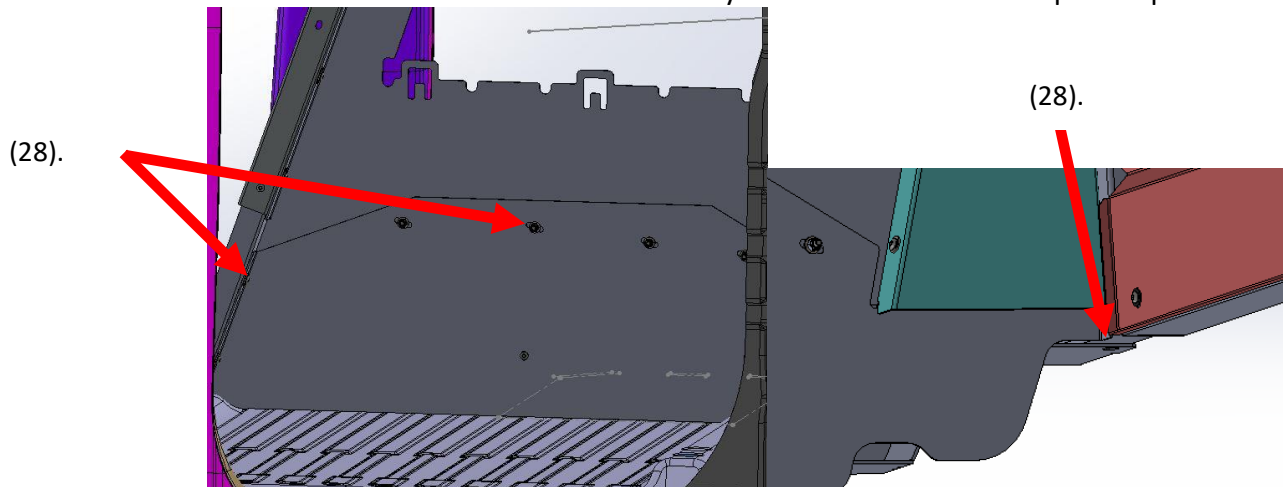

28.) Fasten ear cover driver side (TP-21F1-SC-#ecd) to #rssa on the driver side using three provided 1/4-20 x 0.75" button head screws with washers.

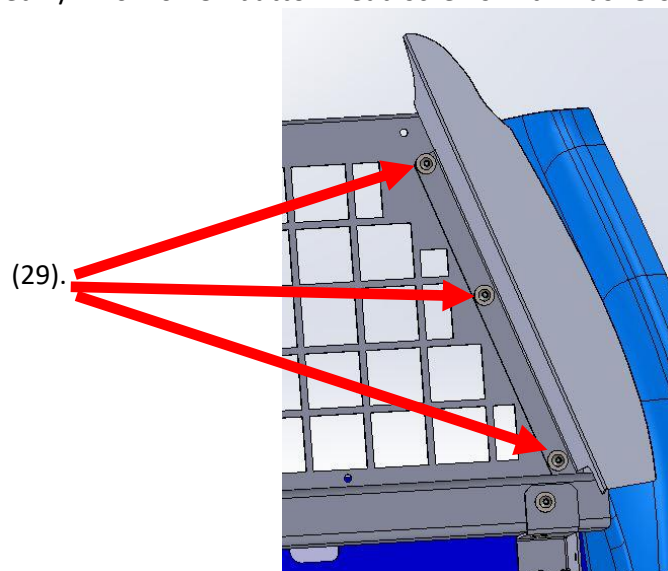

29.) Fasten ear cover passenger side (TP-21F1-SC-#ecp) to #rssa on the passenger side using three provided 1/4-20 x 0.75" button head screws with washers.

(30).

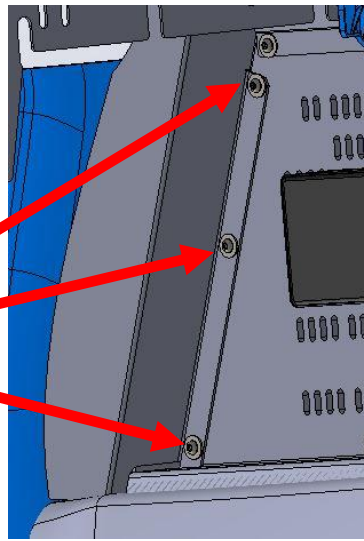

- 30.) Reattach #rfa to #sp, make sure to loosen the plungers in #rfa.
- a. Once #rfa is back in place put the two provided quarter turn receptables back into #spa.
- 31.) Remove the two provided 1/4-20 x 0.625" button head screws with washers that are connecting #kp and #FB1 and then place lower wing panel (TP-21F1-SC-#lwp) and put those screws back in through all three parts.
- a. Then finish fastening #lwp through #wa using three provided 1/4-20 x 0.625" button head screws with washers and nylon locknuts.

(32a).



(32).

- 32.) Attach the storage tongue to #lwp using two provided #10 x 1" sheet metal screws using a 5/16" socket and align it based on the image shown below.

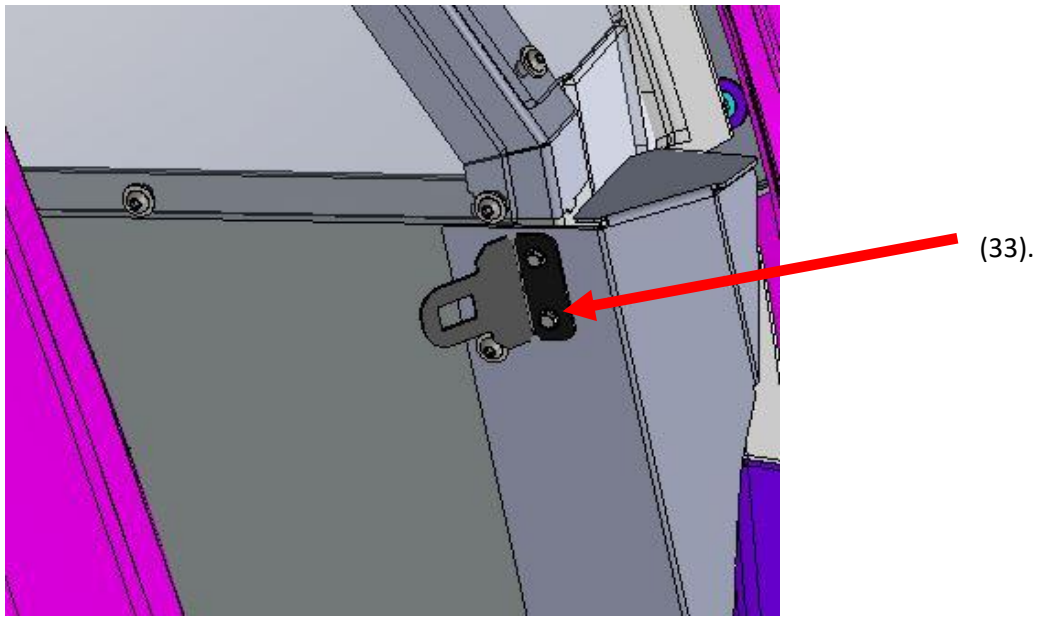

**III.) Molle Panel (SOLD SEPARATELY, SKIP THIS SECTION IF AC-21F1-MOL-DS WAS NOT PURCHASED.)**

33.) Enlarge the existing hole shown in the image below to 25/64”.

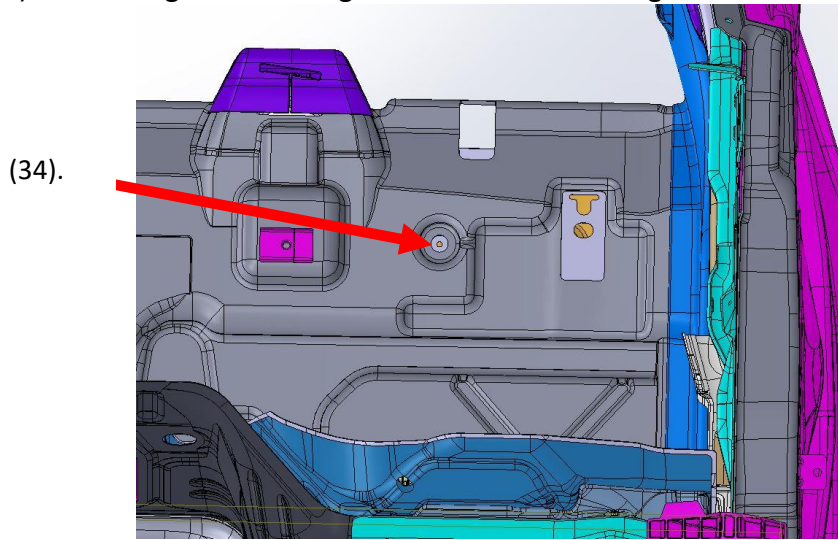

- 34.) Insert the provided 1/4-20 rivet nut into the hole drilled in the previous step. The rivet nut can be installed with a rivet gun or using a screw and a lock washer as shown below.

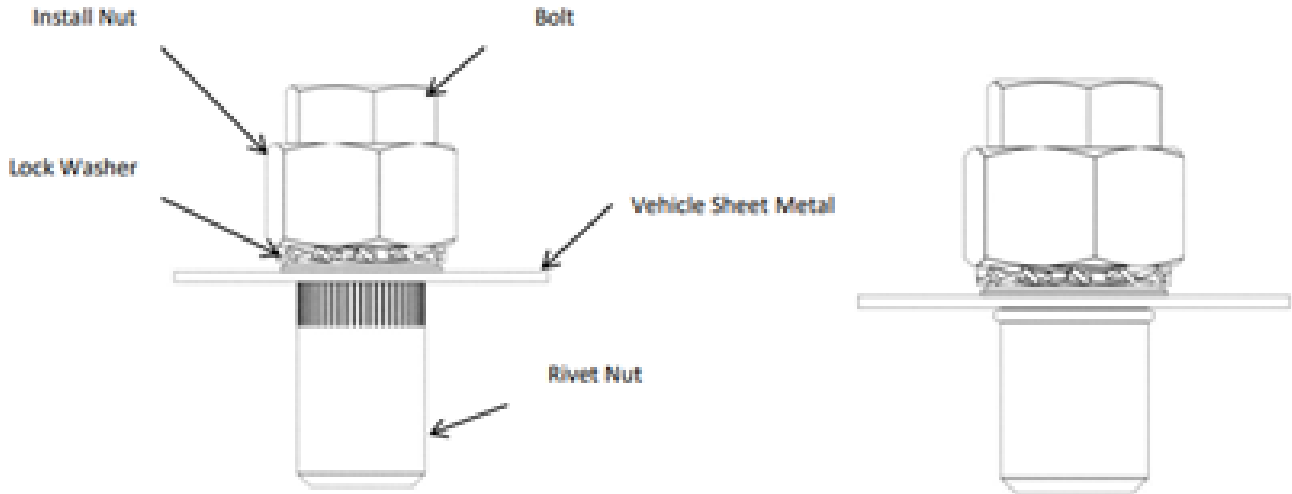

- 35.) Attach the rubber latch to the foot bracket (AC-21F1-MOL-DS-#fbw) using two provided 10-32 x 0.625" button head screws and nylon lock nuts as shown in the image below. Also attach two provided grey rubber bumpers to #fbw as shown in the image as well.

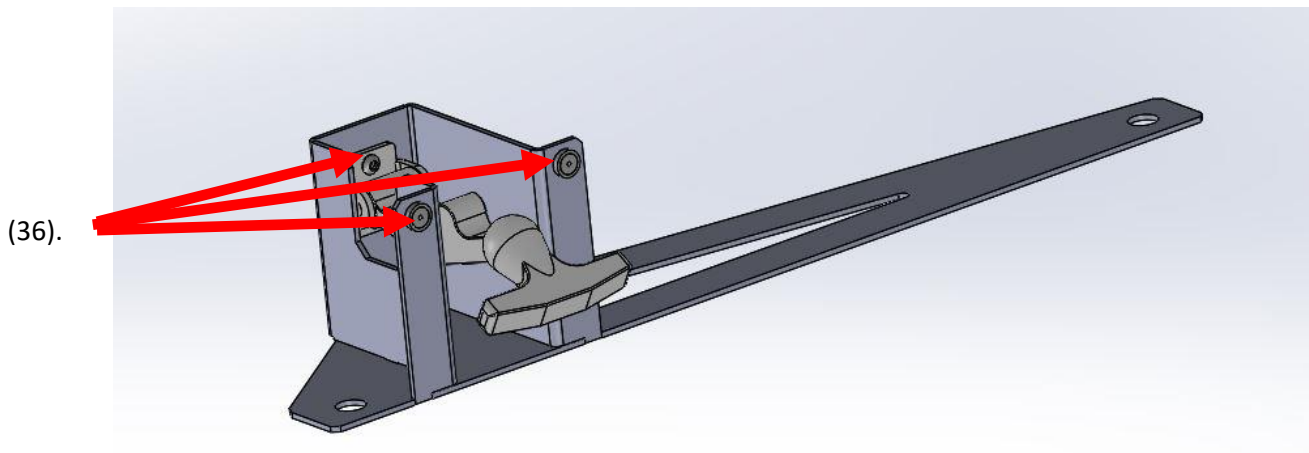

- 36.) Then place #fbw into the vehicle. It fits over OEM studs as shown in the image below. Only put on the OEM nut closest to the driver side in this step.

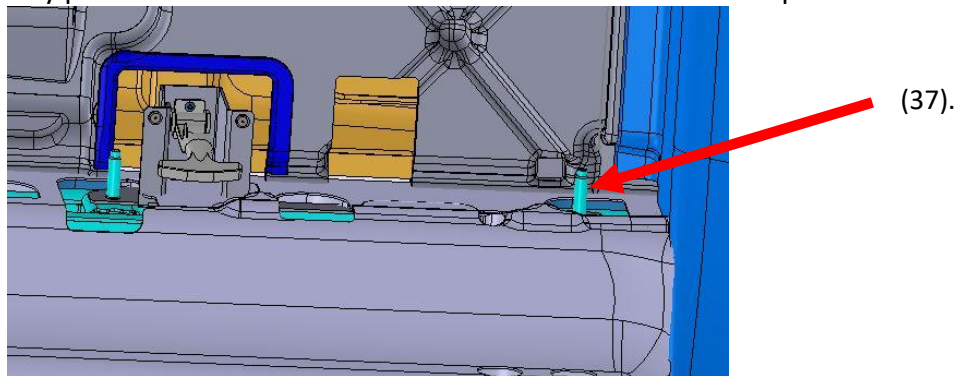

- 37.) Attach the gas spring to the gas spring bracket (AC-21F1-MOL-DS-#gsbw) using a provided 5/16-18 nylon lock nut using a 1/2" socket. Make sure to place the gas spring into the bracket as shown below. Once that is done put #gsbw into the vehicle as shown below. Using a provided 1/4-20 x 2" button head screw, a washer and the provided

spacer (RP-21TH-#tub), secure #gsbw into position using the rivet nut inserted in the vehicle in step 35 as shown below. Put the OEM nut back on the other OEM stud.

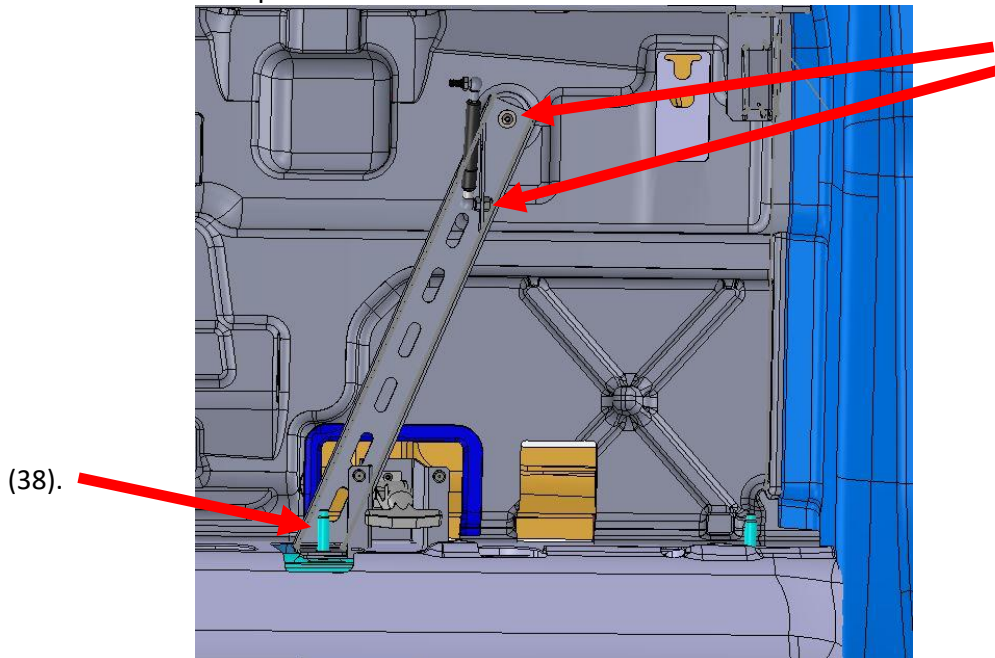

(38).  
The tank of the gas spring should be pointing towards the roof of the vehicle

38.) Assemble the driver and passenger side pivot brackets (AC-21F1-MOL-DS-#dpiv and AC-21F1-MOL-DS-#ppiv) using hinge bracket 1 which has the locator hole (AC-21F1-MOL-DS-#hng1) and hinge bracket 2 (AC-21F1-MOL-DS-#hng2) as shown below before inserting it in the vehicle using one provided 1/4-20 x 1" button head screw, one provided nylon spacer, and a provided nylon lock nut between #dpiv and #hng2 and then a provided 1/4-20 x 1.5" button head screw and a provided nylon lock nut between #hng2 and #hng1. #dpiv is shown in the image below. **Ensure the locator hole in #hng1 is matching the image below.** #ppiv is a mirror part and will be assembled in the same way.

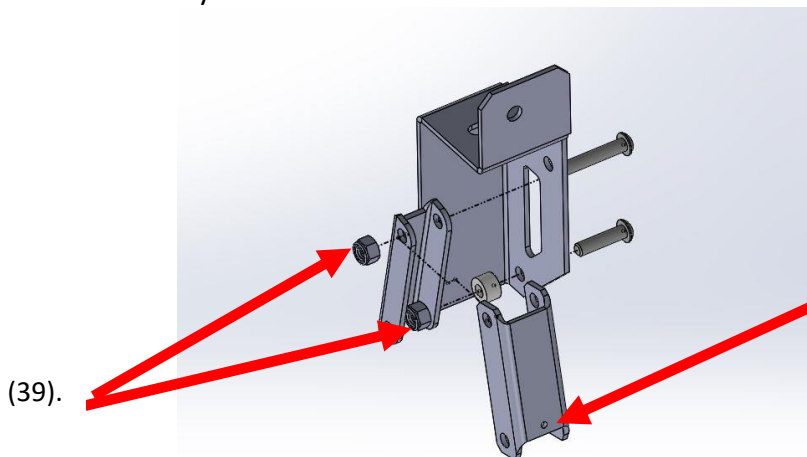

Locator hole must be in the same orientation

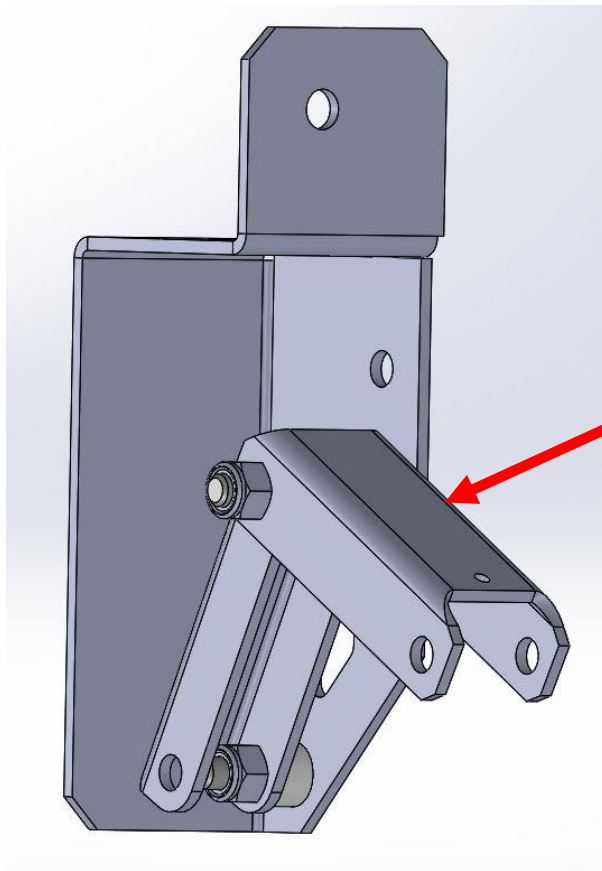

The part should look like this when assembled

39.) Attach #ppiv and #dpiv into the vehicle as shown in the image below to the seat bar from the single cell with #dpiv being closest to the driver side using two provided 1/4-20 x 0.75" button head screws and washers for each side.

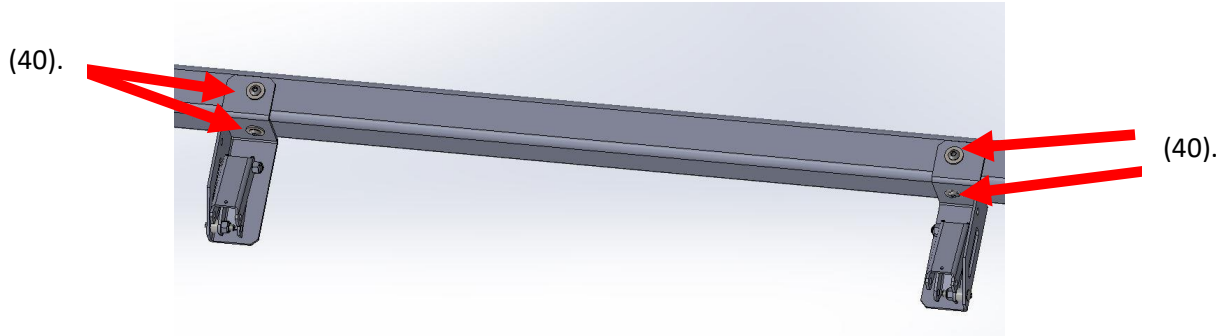

40.) Attach gas spring bracket 2 (AC-21F1-MOL-DS-#gbs2) to molle tray (AC-21F1-MOL-DS-#pan) using four provided 1/4-20 x 0.75" button head screws and nylon lock nuts. Attach the receptacle of the handle onto #pan using two provided 10-32 x 0.625" button head screws and nylon lock nuts.

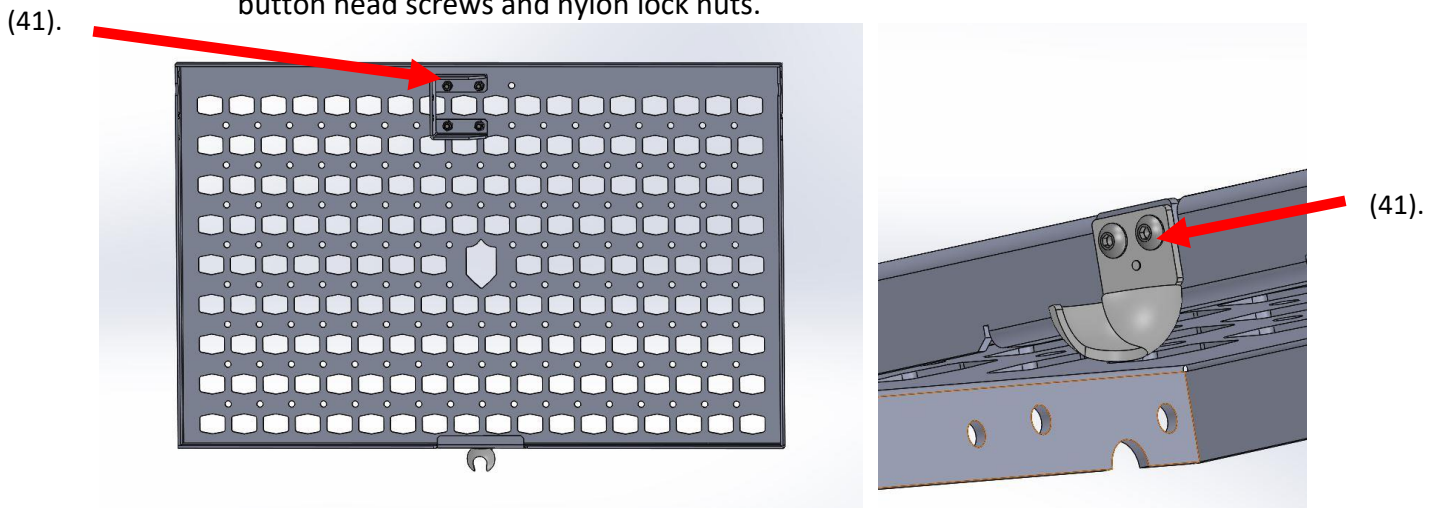

41.) Attach #pan into the vehicle through #ppiv and #dpiv using one provided 1/4-20 x 0.75" button head screw and nylon lock nut on each side as shown in the image below. (#ddiv is shown below.)

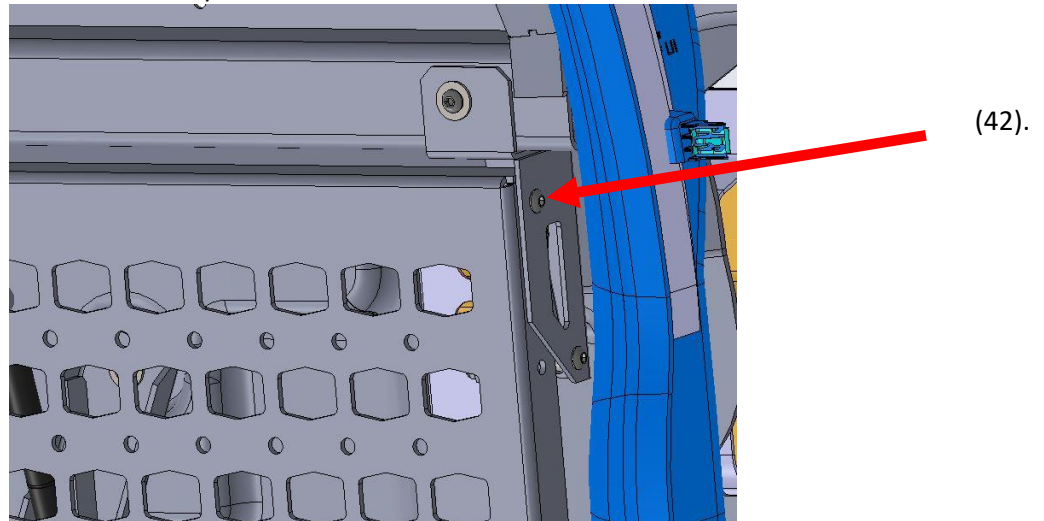

- 42.) Attach the other end of the gas spring to #gsb2 as shown below using a provided 5/16-18 nylon lock nut.

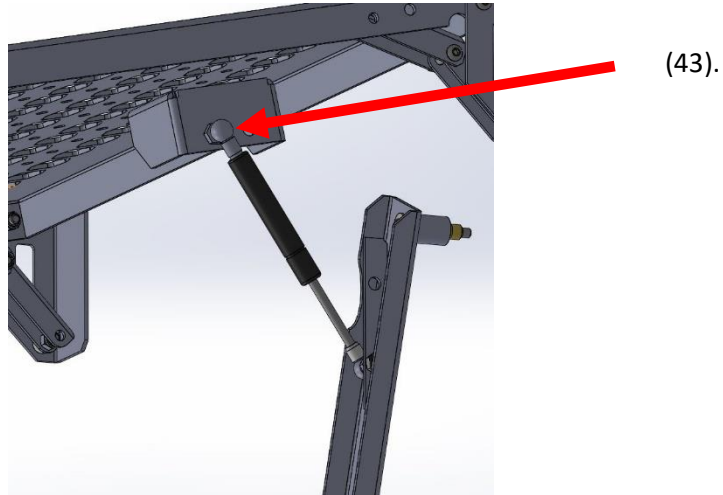

- 43.) Attach #pan through #hng1 on both sides using one provided 1/4-20 x 1.5" button head screw and a nylon lock nut on each side as shown below.

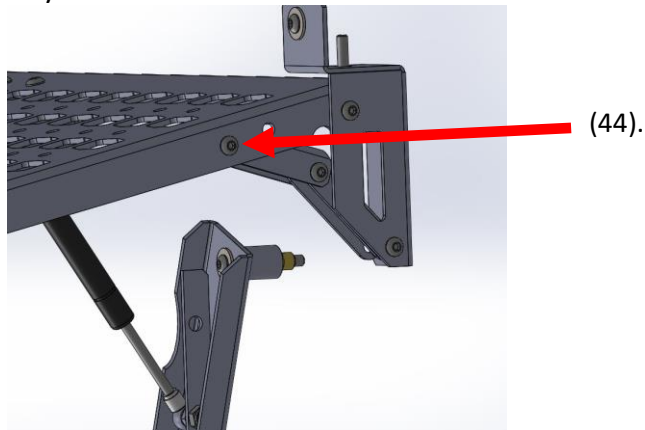

Your installation is now complete. If you have any questions or suggestions for adding additional instructions, please call **Customer Service at (800) 700-8769.**

6 5 4 3 2 1

REVISIONS		DATE	APPROVED
ZONE	REV.	DESCRIPTION	DATE
	A	ADDED DRAWING QTY'S	11/11/2024
			SP

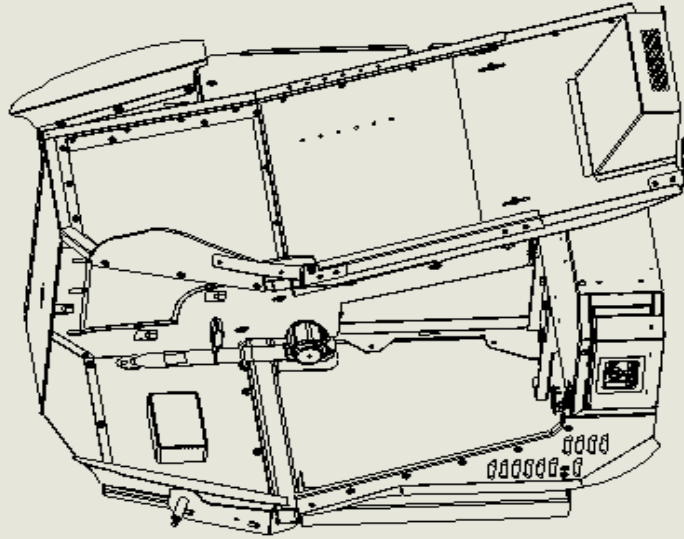

ITEM NO.	PART NUMBER	DESCRIPTION	QTY
1	TP-21F1-SC-#luba	TOP BAR ASSEMBLY	1
2	TP-21F1-SC-#kp	KICK PANEL WELDMENT	1
3	TP-21F1-SC-#tp	HEADLINER PANEL	1
4	TP-21F1-SC-#sgpp	SIDE GAP PANEL PASSENGER	1
5	TP-21F1-SC-#box	2021 F150 SINGLE CELL UNDER SEAT BOX	1
6	TP-21F1-SC-#cba	COMBINATION BRACKET ASSEMBLY	1
7	TP-21F1-SC-#rssa	REAR SCREEN ASSEMBLY	1
8	TP-21F1-SC-#spl	LOWER SIDE PANEL	1
9	TP-21F1-SC-#bbp	B-PILLAR BRACKET	1
10	TP-21F1-SC-#FB1	FOOT BRACKET 1	1
11	TP-21F1-SC-#FB2	INNER FOOT BRACKET	1
12	TP-21F1-SC-#b	BRACKET	1
13	PS-21F1-BNCHST-#gpb	GAP PANEL BRACKET	1
14	TP-21F1-SC-#lwp	LOWER WING PANEL	1
15	PLS-TP-21F1-SC-#bp	PASSENGER WING	1
16	TP-21F1-SC-#wa	FRONT PARTITION ASSEMBLY	1
17	TP-21F1-SC-#ecc	DRIVER EAR COVER	1
18	TP-21F1-SC-#ECP	PASSENGER EAR COVER	1
19	TP-21F1-SC-#spq	SIDE PANEL ASSEMBLY	1
20	TP-21F1-SC-#hw	Loose hardware	1
21	P21F1-31(b)	2021 F150 SINGLE CELL PLASTIC SEAT	1
22	T-P21F101KIT	PTS F150 KIT BOX	1
23	3-PAK-62102B	Box, 62" x 10-3/4" x 28" - FOL w/4 HH	1
24	3-PAK-60054S	Box 60" x 5" x 45"	1
25	TP-21F1-SC-#edc	Electronics Drawer Cover	1
26	EM-21F1-ECOVER-2ROW-#ep	ELECTRONICS PAN	1
27	EM-21F1-ECOVER-2ROW-#fb	FLOOR BRACKET	1
28	TP-21F1-SC-#ds	DRIVER SIDE STRAP	1
29	TP-21F1-SC-#ps	PASSENGER SIDE STRAP	1

Box # 1  
Box # 1  
Box # 2



**PROPRIETARY AND CONFIDENTIAL:**  
THE INFORMATION CONTAINED IN THIS DRAWING IS THE SOLE PROPERTY OF TROY PRODUCTS AND IS NOT TO BE REPRODUCED OR TRANSMITTED IN ANY FORM OR BY ANY MEANS, ELECTRONIC OR MECHANICAL, INCLUDING PHOTOCOPYING, RECORDING, OR BY ANY INFORMATION STORAGE AND RETRIEVAL SYSTEM, WITHOUT PERMISSION OF TROY PRODUCTS IS FORBIDDEN.

UNLESS OTHERWISE SPECIFIED:	NAME	DATE	TITLE
DIMENSIONS ARE IN INCHES	PFM	11/11/2021	2021 F150 SINGLE CELL
FRACTIONAL	JAC		
ANGULAR DIMENSIONS	DESIGNER		
TRIG PLACE DECIMAL	ENG. APPL.		
THREE PLACE DECIMAL	MPG. APPR.		
1. EXCEPT FOR NON-FERROUS	Q.A.		
2. DIMENSIONS TO CENTERLINE UNLESS NOTED OTHERWISE	COMMENTS:		
MATERIAL			
FINISH			
DO NOT SCALE DRAWING			

SIZE	DWG. NO.	REV
B	TP-21F1-SC	A
SCALE: 1:10		SHEET 1 OF 2

6 5 4 3 2 1

6 5 4 3 2 1

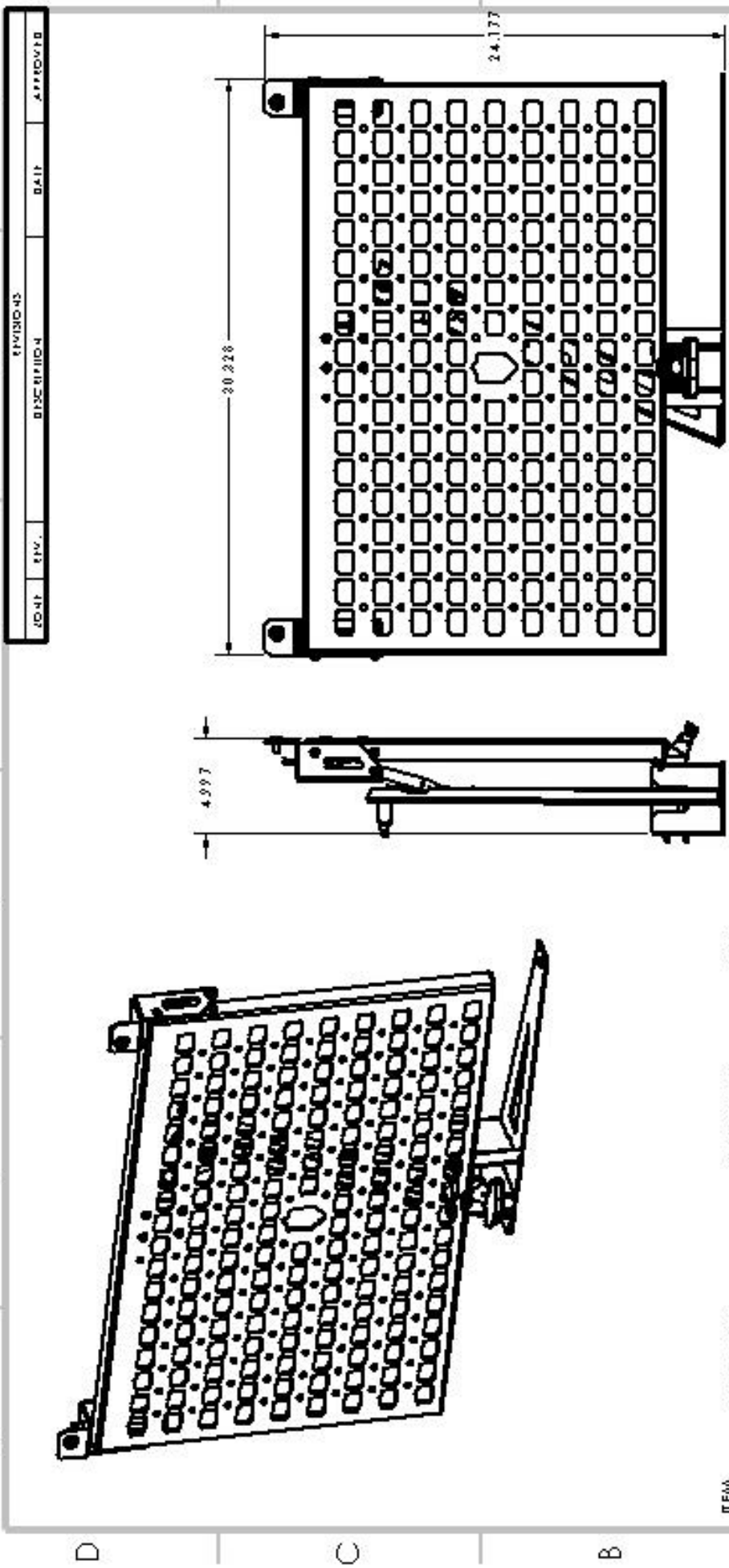

ITEM NO.	PART NUMBER	DESCRIPTION	QTY.
1	A-C-21F1-MOL-DS-#g-ab-w	GAS SPRING BRACKET WELDMENT	1
2	A-C-21F1-MOL-DS-#g-ab-2	GAS SPRING BRACKET 2	1
3	A-C-21F1-MOL-DS-#d-piv	DRIVER PIVOT	1
4	A-C-21F1-MOL-DS-#p-piv	PASSENGER PIVOT	1
5	A-C-21F1-MOL-DS-#hng-1	HINGE 1	2
6	A-C-21F1-MOL-DS-#hng-2	HINGE 2	2
7	A-C-21F1-MOL-DS-#pan	MOLLE PANEL	1
8	A-C-21F1-MOL-DS-#fb-w	FLOOR BRACKET WELDMENT	1
9	A-C-21F1-MOL-DS-#hw	LOOSE HARDWARE	1



FOR ALL INFORMATION CONTACT TROY PRODUCTS AT 1-800-368-7777. TROY PRODUCTS IS AN ISO 9001:2015 CERTIFIED COMPANY.

UNLESS OTHERWISE SPECIFIED	DATE	BY	APPR.	TITLE
DESIGN	2/14/2022	PFM	2/14/2022	2021 F150 SINGLE CELL MOLLE PANEL
ENGINEER		PFM		
DATE				
SCALE				
REV				
NO	NO	NO	NO	NO
DATE				