



Mar. 23, 2023

A division of Troy Sheet Metal Works, Inc.
1024 South Vail Avenue, Montebello, CA 90640
www.troyproducts.com 323 720-4100

Revision 0

Part No: RP-21TH-2-XX / PS-21TH-MNT-2
Description: 2021+ Tahoe rear partition (Second Gen.)

Vehicle: Chevrolet Tahoe
Model year: 2021+



Tools Required:	Ø7/8" hole saw Metric socket set	Rotatory tool SAE socket set	SAE Allen keys set Drill	Utility knife Socket extensions
------------------------	-------------------------------------	---------------------------------	-----------------------------	------------------------------------

Troy Products recommends reading through all installation instructions prior to installation to check all necessary parts have been included (check against bill of materials table.)

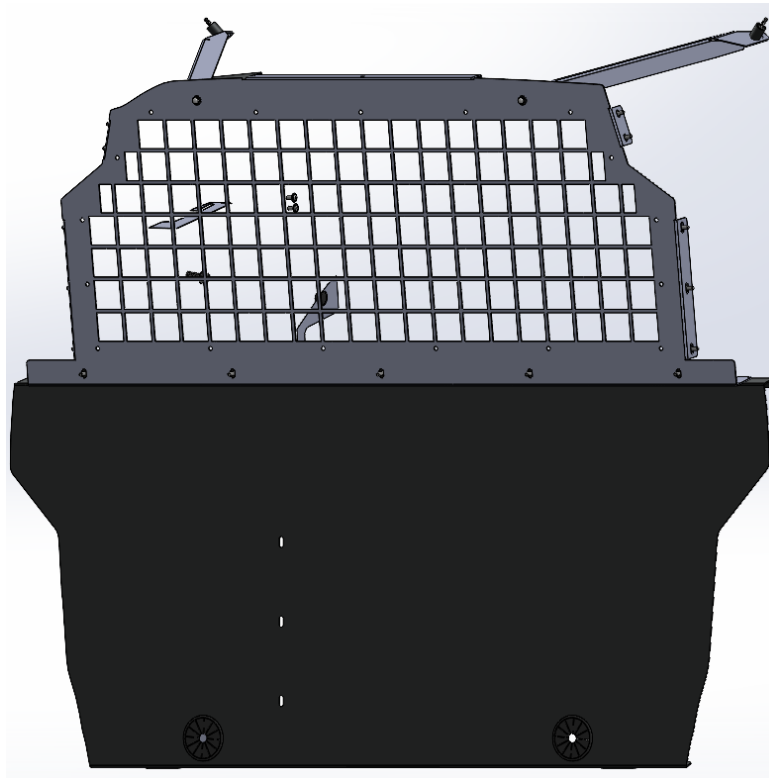

Quick Guide



1. Prep vehicle by cutting floor rubber mat for installation of foot brackets.
2. Trim away drivers and passenger sides plastic panels at cargo area.
3. Drill passenger side plastic panel at cargo area.
4. Remove coat hooks and 3rd row seatbelt plastic covers.
5. Install foot brackets.
6. Install upper brackets.
7. Install lower brackets.
8. Install partition lower panel.
9. Install partition upper panel.
10. Install corner braces.
11. Install side panels.

RP-21TH-2-XX - BILL OF MATERIALS

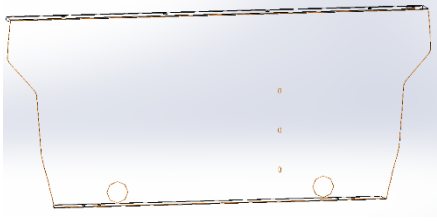
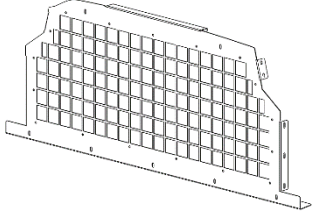
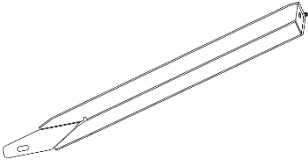
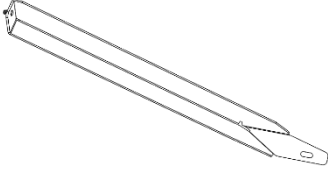
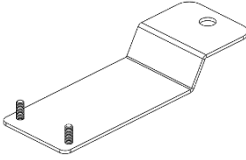
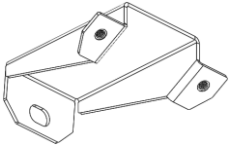
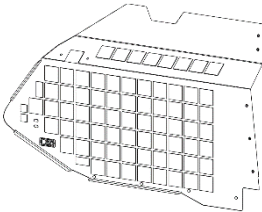
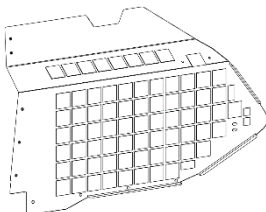
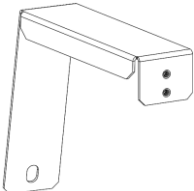
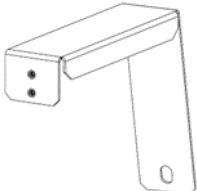
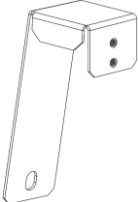
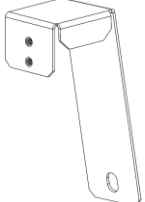
(DEPENDING ON PURCHASED PARTITION TYPE, INCLUDED PARTS WILL VARY)

PARTS	
<p>Part number: RP-21TH-#lp</p> <p>Description: LOWER PANEL</p> <p>QTY: 1</p> 	<p>Part number: P/N varies depending on partition version, Sq. punch panel shown.</p> <p>Description: UPPER PANEL</p> <p>QTY: 1</p> 
<p>Part number: RP-21TH-2-#dbrc</p> <p>Description: DRIVER CORNER BRACE</p> <p>QTY: 1</p> 	<p>Part number: RP-21TH-2-#pbrc</p> <p>Description: PASSENGER CORNER BRACE</p> <p>QTY: 1</p> 
<p>Part number: RP-21TH-#f</p> <p>Description: FOOT BRACKET</p> <p>QTY: 2</p> 	<p>Part number: RP-AC-21TH-SQ-#ch</p> <p>Description: UPPER BRACKET</p> <p>QTY: 2</p> 
<p>Part number: P/N varies depending on partition version, Sq. punch panel shown.</p> <p>Description: DRIVER SIDE PANEL</p> <p>QTY: 1</p> 	<p>Part number: P/N varies depending on partition version, Sq. punch panel shown.</p> <p>Description: PASSENGER SIDE PANEL</p> <p>QTY: 1</p> 
<p>Part number: RP-AC-21TH-SQ-DS-#b (LONG BRACKET)</p> <p>Description: DRIVER SIDE LOWER BRACKET FOR SQ. PUNCH SIDE PANEL ONLY</p> <p>QTY: 1</p> 	<p>Part number: RP-AC-21TH-SQ-PS-#b (LONG BRACKET)</p> <p>Description: PASSENGER SIDE LOWER BRACKET FOR SQ. PUNCH SIDE PANEL ONLY</p> <p>QTY: 1</p> 
<p>Part number: RP-AC-21TH-DSL-#b (SHORT BRACKET)</p> <p>Description: DRIVER SIDE LOWER BRACKET FOR FIRE EXTINGUISHER AND LOCKING COMPARTMENT SIDE PANEL TYPES</p> <p>QTY: 1</p> 	<p>Part number: RP-AC-21TH-PSL-#b (SHORT BRACKET)</p> <p>Description: PASSENGER SIDE LOWER BRACKET FOR FIRE EXTINGUISHER AND LOCKING COMPARTMENT SIDE PANEL TYPES</p> <p>QTY: 1</p> 

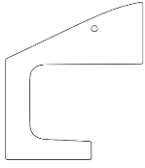
HARDWARE

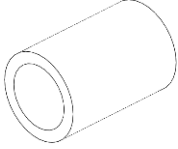
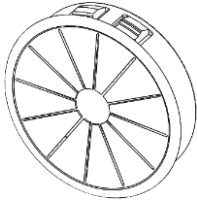
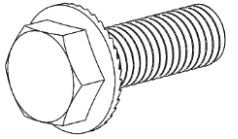
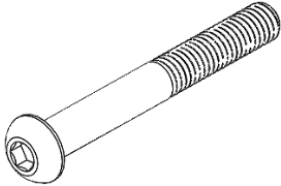
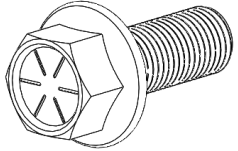
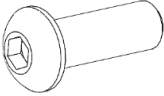
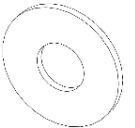
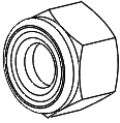
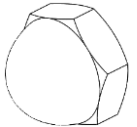
<p>Part number: RP-21TH-#btmtemp</p> <p>Description: BOTTOM TEMPLATE</p> <p>QTY: 1</p>		<p>Part number: RP-21TH-#toptemp</p> <p>Description: TOP TEMPLATE</p> <p>QTY: 1</p>	
<p>Part number: RP-21TH-#tub</p> <p>Description: 1-1/8" SPACER</p> <p>QTY: 2</p>		<p>Part number:</p>	
<p>Part number: AC-3WGROM</p> <p>Description: 3" WIRING GROMMET</p> <p>QTY: 1</p>		<p>Part number: 1-FST-09-M1030</p> <p>Description: M10-1.5 X 30mm FLANGE HH BOLT</p> <p>QTY: 2</p>	
<p>Part number: 1-FST-05-M6150</p> <p>Description: M6-1 X 50mm BH SCREW</p> <p>QTY: 2</p>		<p>Part number: 1-FST-10-66321</p> <p>Description: 7/16-20 X 1-1/8" TRI-LOBE HH BOLT</p> <p>QTY: 4</p>	
<p>Part number: 1-FST-06-60825</p> <p>Description: 1/4-20 X 5/8" BH SCREW</p> <p>QTY: 28</p>		<p>Part number: 1-FST-50-60800</p> <p>Description: 1/4 FLAT WASHER, BLK ZINC</p> <p>QTY: 36</p>	
<p>Part number: 1-FST-35-31000</p> <p>Description: #1/4-20 NYLON NUT</p> <p>QTY: 14</p>		<p>Part number: 1-FST-36-60800</p> <p>Description: 1/4-20 ACORN NUT, ZINC</p> <p>QTY: 2</p>	

If a plastic seat mount is to be installed, the OEM second seat belts need to be prep prior installing the rear cage in the following manner:

A – Remove OEM seats if applicable.

B - Remove upper and lower C-Pillar trims.

C - Disconnect OEM seatbelts end from C-Pillar at top and bottom mounting points.

D - Roll up seat belts & secure with zip ties.

E - Re install C-Pillar trim and tuck zip tied seatbelts behind it.

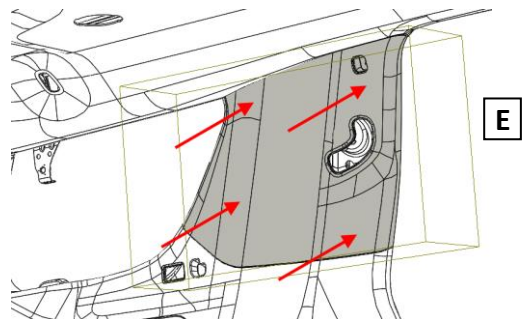
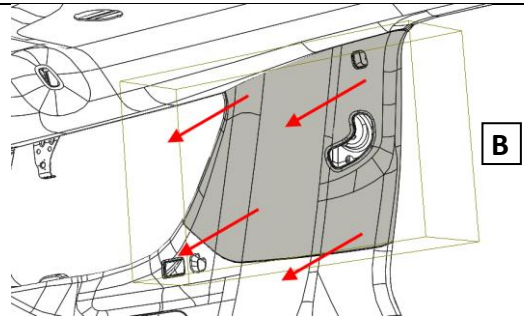

Proceed with rear cage installation.

Rear cage cargo area preparation

- 1.) Cut crosses on rubber mat where marked to allow mounting screws to get installed. Driver side mount point is shown in photograph, passenger mount point is symmetrical location roughly 5-7/8" inboard of plastic panels.

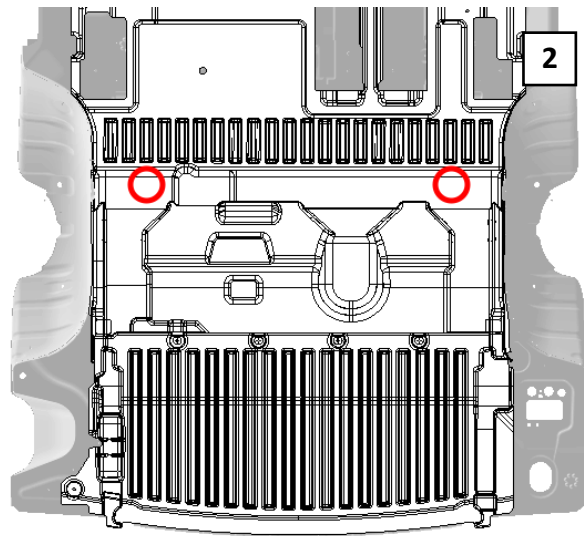

- 2.) Place the top template on the driver side plastic panel, mark and trim away the rectangular section. Use a rotatory tool, shears, or a suitable tool.

Repeat steps on passenger side plastic panel by flipping the top template.



- 3.) Place the bottom template on the passenger side plastic panel where shown, mark and drill a 7/8" hole using a circular saw.

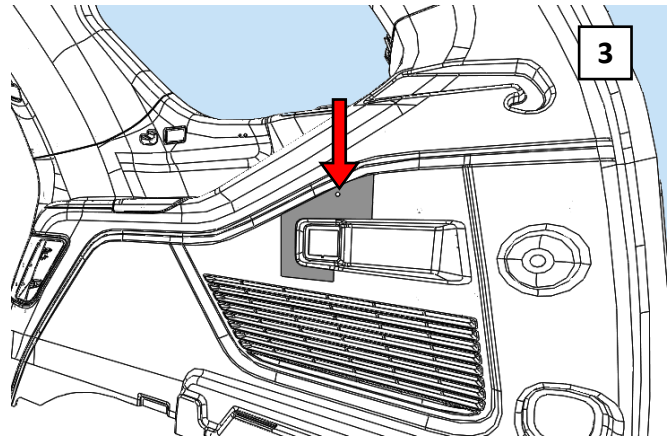

- 4.) Remove driver and passenger coat hooks from head liner using an 8MM socket. Remove driver and passenger 3rd row seat belt upper mount covers by splitting the halves open and pulling downwards.

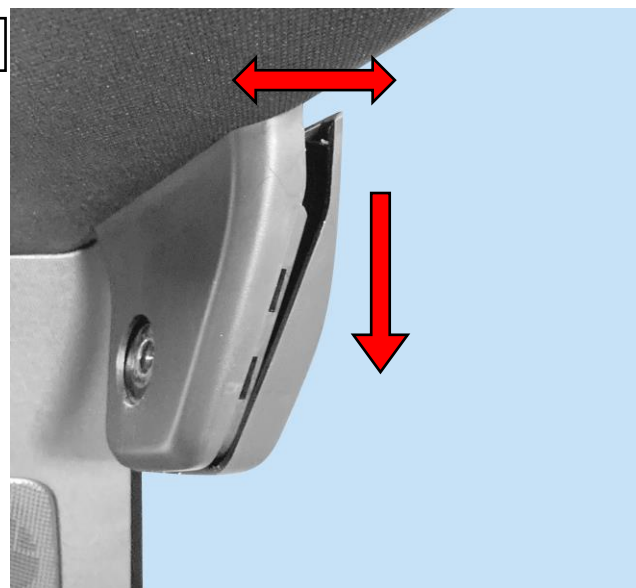
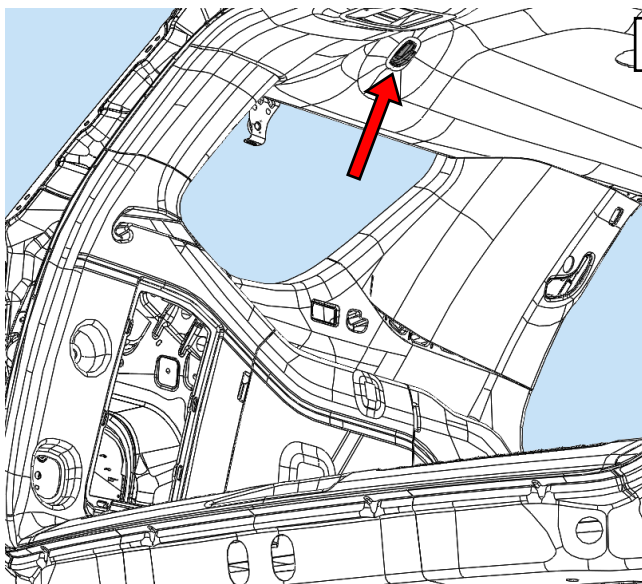

- 5.) Install foot brackets as shown using (2) M10-1 X 30mm. Bolts, on mounting points from **STEP 1**. Bolts are to pass through cross cuts from rubber mat. **DO NOT TIGHT BOLTS AT THIS TIME.**

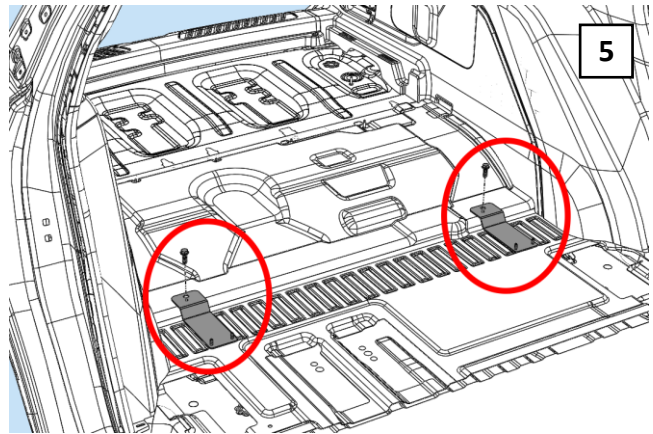

- 6.) Install upper brackets on driver and passenger side exposed 3rd row seat belt upper mount point as shown using (2) 7/16-20 X 1-1/8" tri-lobe bolts. **DO NOT TIGHT BOLT AT THIS TIME.**

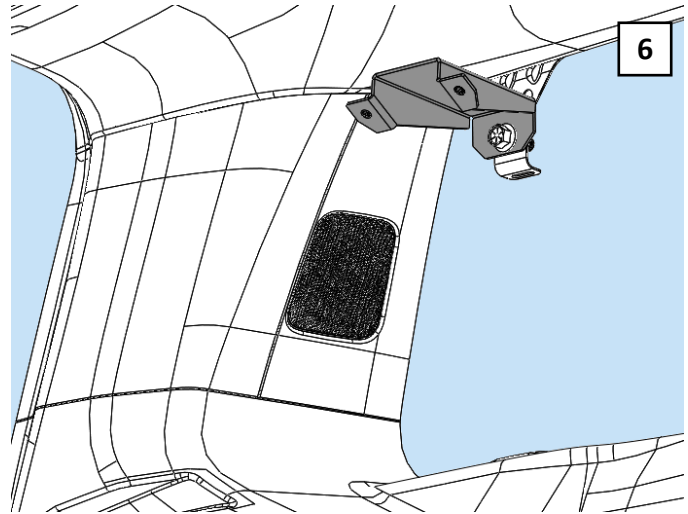

- 7.) Insert lower brackets through plastic panels and install to lower belt mounting points.

7a.) Insert lower brackets on cutout from **STEP 2** as shown (bracket side bend to be orientated towards vehicle rear), on driver side open the fuse cover from the plastic panel and manage to align the bracket mount hole with the lower seat belt mount point as shown, secure bracket using (1) 7/16-20 X 1-1/8" tri-lobe HH bolt.

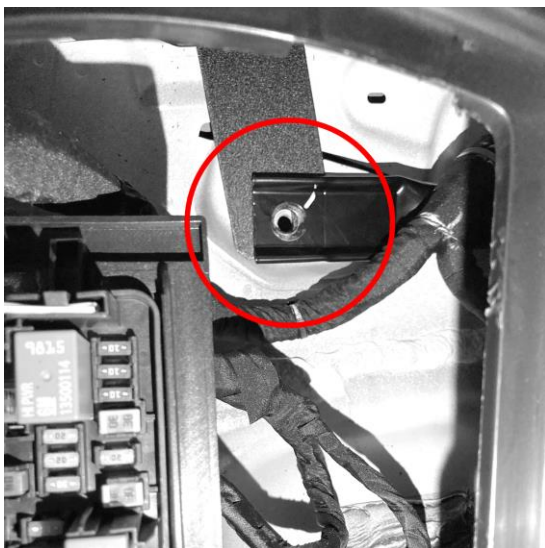

7a

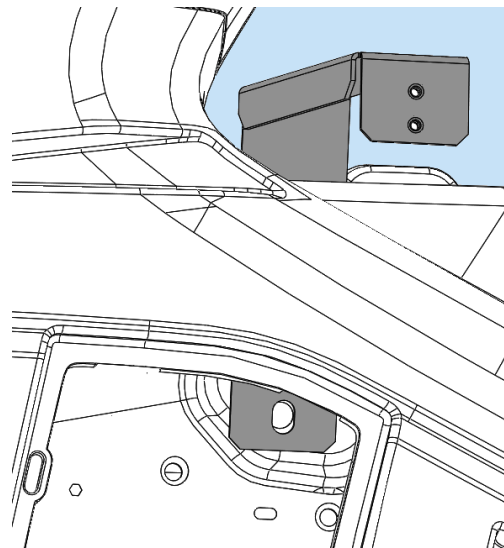

7b.) On passenger side insert the lower bracket as shown on cutout made from **STEP 2**, manage to align bracket mount hole with lower seat belt mount, use a socket extension to install bracket using from access hole made from **STEP 3** with (1) 7/16-20 X 1-1/8" tri-lobe HH bolt.

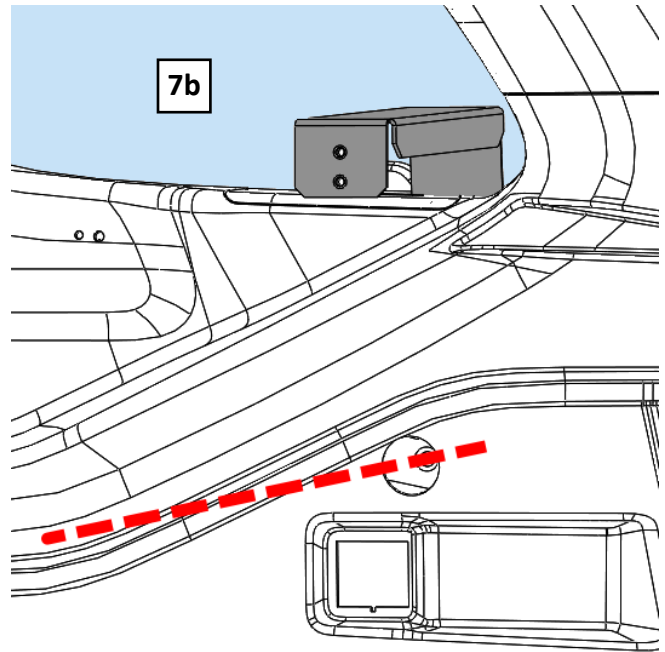

8.) Bring partition lower panel in place and secure it to foot brackets using a total of (4) 1/4-20 nylon lock nuts and washers from cargo area. **DO NOT TIGHT BOLTS AT THIS TIME.**

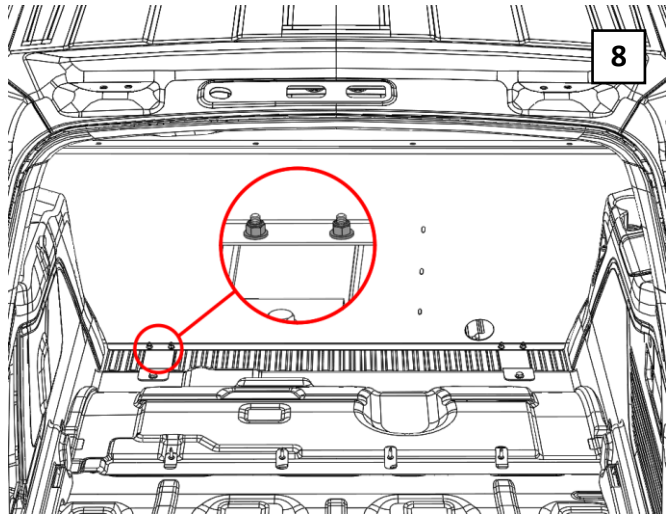

9.) From cargo area set partition upper panel and secure it to lower panel with (4) 1/4-20 X 5/8" BH screws (8) washers, one per fastening side and (4) 1/4-20 nylon lock nuts. **DO NOT TIGHT BOLTS AT THIS TIME.**

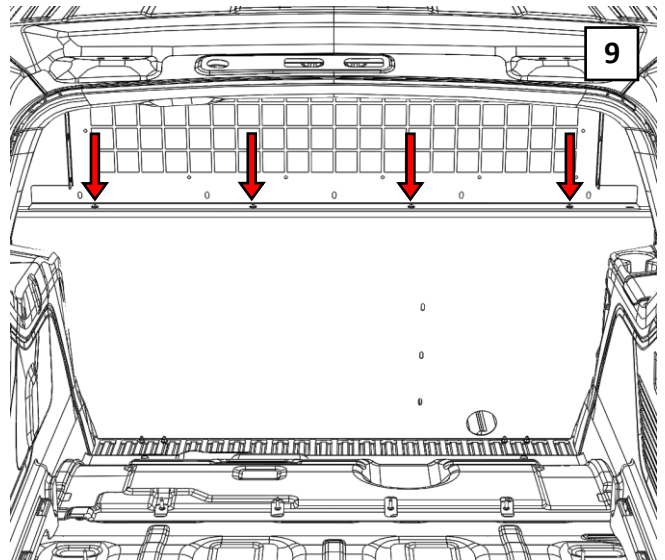

- 10.) From cargo area Install the driver side corner brace to coat hanger mounting point using (1) 1-1/8" spacer, (1) M6-1 X 50mm screw and (1) washer, do not fully tight hardware yet. From second row seats area manage to insert the threaded studs into the shown hole of the partition upper panel, tightly secure brace with (1) 1/4-20 acorn nut, fully tight hardware from cargo area at this point. **REPEAT STEPS ON PASSENGER SIDE.**

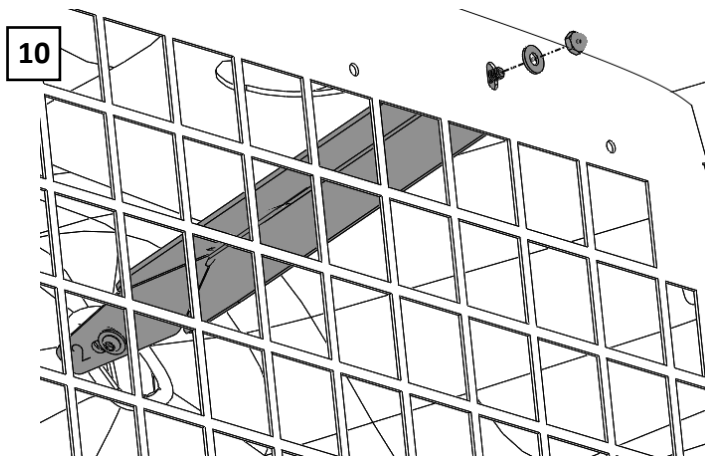
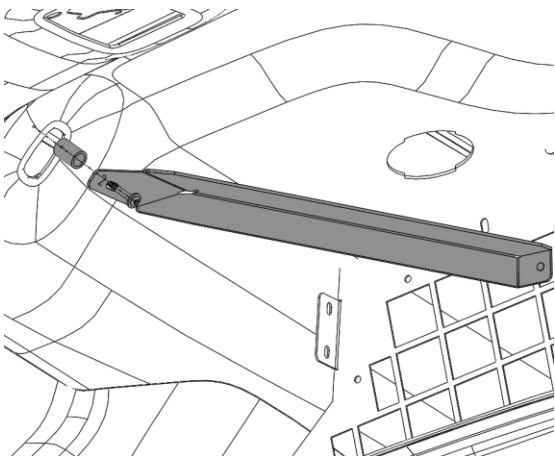

- 11.) Bring driver side panel in position as shown and secure it to upper bracket with (2) 1/4-20 X 5/8" BH screws, secure side panel to lower bracket with (2) 1/4-20 X 5/8" BH screws and washers, secure side panel to partition upper panel with (5) 1/4-20 X 5/8" BH screws and washers.

REPEAT STEPS ON PASSENGER SIDE.

TIGHTEN ANY LOOSE HARDWARE FROM PREVIOUS STEPS AT THIS POINT.

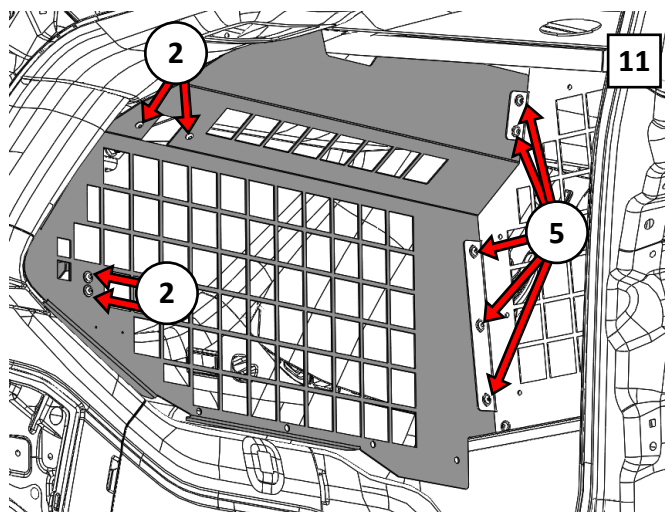

- 12.) Insert wiring grommet in position.

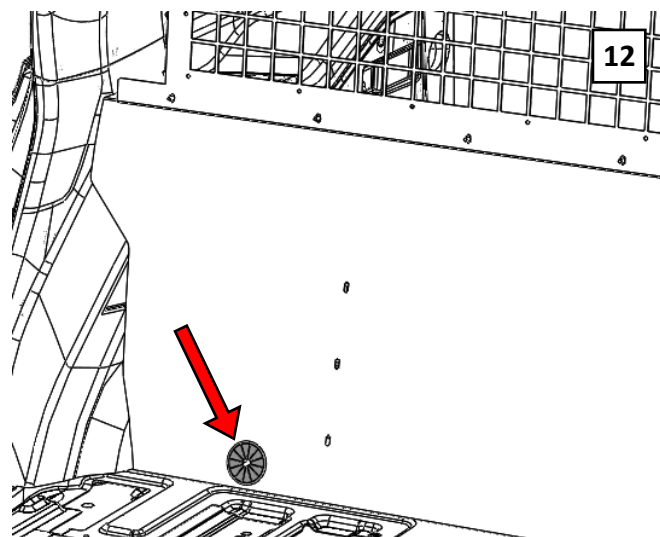

Installation of plastic seat (Continued)

NOTE: Install floor pan before seat (optional).

Caution: Locate all wiring, fuel lines, and cooling lines before drilling holes or installing fasteners.

	Required Tools <ul style="list-style-type: none">● Power Drill● 1/8" Drill Bit● 1-1/4" Hole Saw● Socket Wrench Set● Allen Key set● T50 Torx Bit● 7/16" wrench	Bolt and Torque Specifications <ul style="list-style-type: none">● 1/4 - 20 = 8.5 ft-lb● 3/8 - 16 = 20 ft-lb● 7/16-14 = 32 ft-lb● 7/16-20 = 35 ft-lb● 10mm = 24 ft-lb● All Seat Belt Bolts = 30-35 ft-lb
---	--	--

Preparation

P1 - Remove OEM second row seats per manufacturer's instructions.

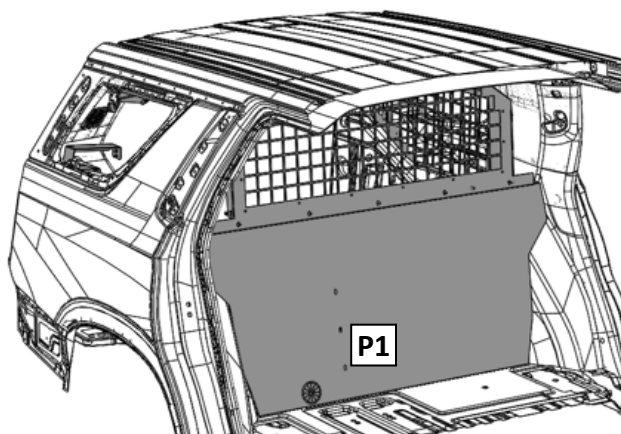

P2 - Using provided drill template (P21T60DT) drill 1/8" pilot hole into C-Pillar trims, follow up with 1 1/4" hole saw to cut out plastic trim.

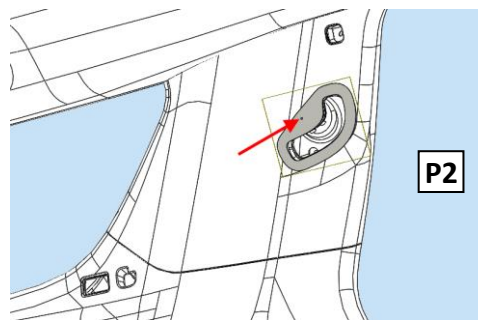

1 - Installation of frame

1a - Install foot weldment bracket using provided spacers (P133) x3 with M10-1.5 x 50mm bolts (P232) x3. Attach to the OEM rear seat anchors in the floorboard (Depending on the model of Tahoe these holes may need to be tapped prior to installation.)

Note: Make sure to have the spacers in place.

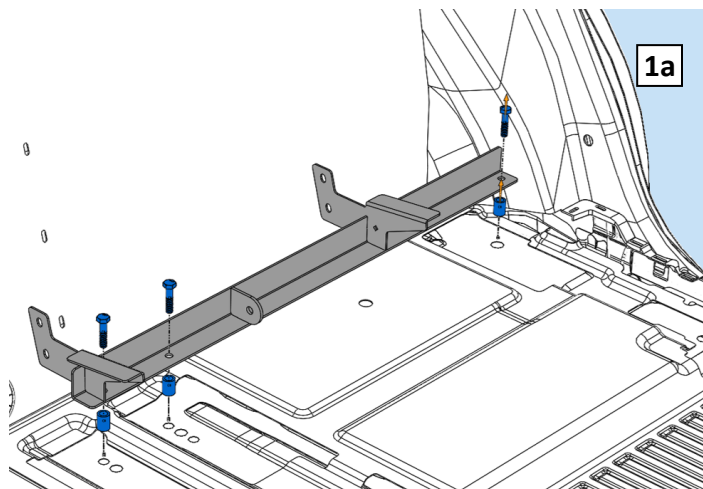

1b - Install legs to foot weldment bracket in the shown orientation using provided 3/8"x 5/8"lg bolts (P208) x4.

Note: only hand tighten at this time.

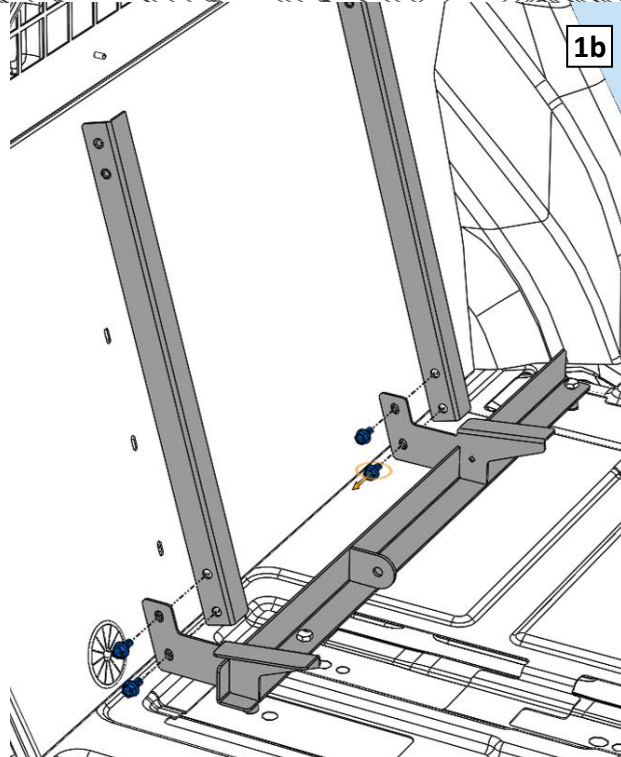

1c - Install stand-off supports x2 on OEM upper seat mount points, install top bar assembly using provided 7/16"-20 x 1" lug hex head screws (P277) x2 with provided lock washers (P266) x2.

Note: only hand tighten at this time.

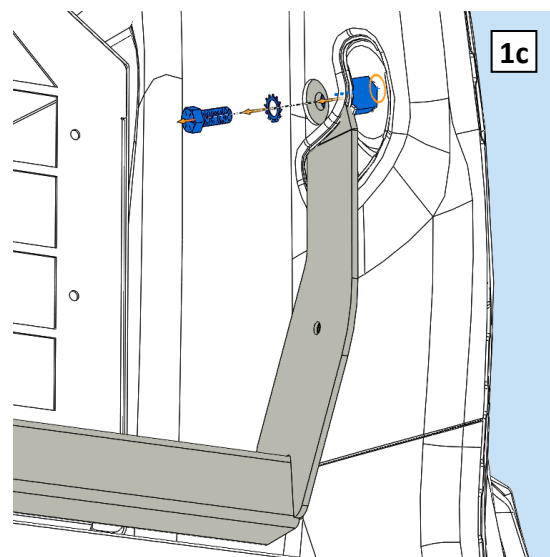

1d - Secure the legs to the bottom of the top bar assembly using the provided 3/8 x 5/8" lg bolts (P208) x4.

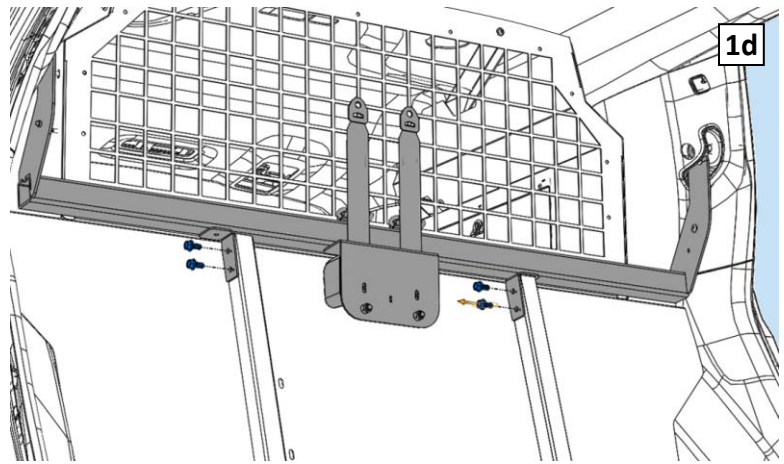

1e - From cargo area secure seat frame to rear partition upper panel using (5) 1/4-20 X 5/8" BH screws and washers.

Note: TIGHTEN ALL FASTENERS AT THIS TIME

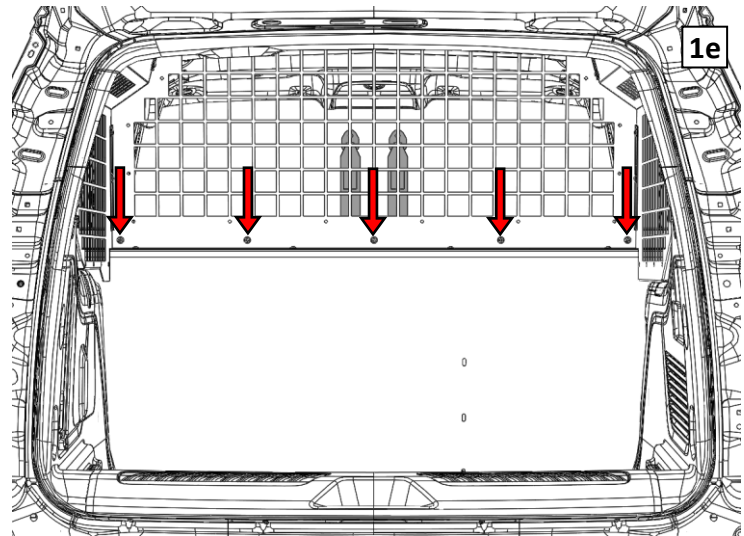

2 - Installation of seat

2a - Attach the hip side tongues (PT81) on both the driver and passenger side as shown in the figure. Passenger side hip tongue requires a spacer (P133) and a M10-1.5 x 50mm bolt (P232). Driver side uses the previously installed hardware from **STEP 1a**.

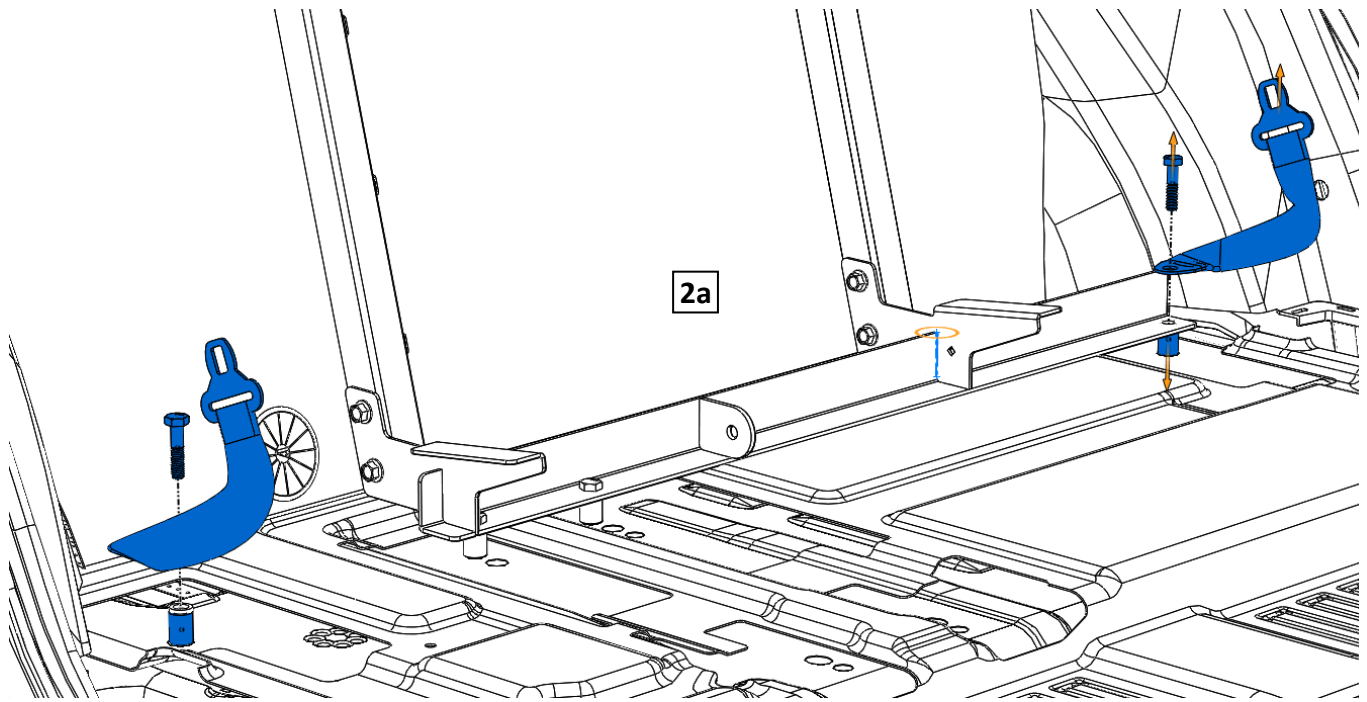

2b – Remove the plastic alignment cover for the stud on the passenger side floor.

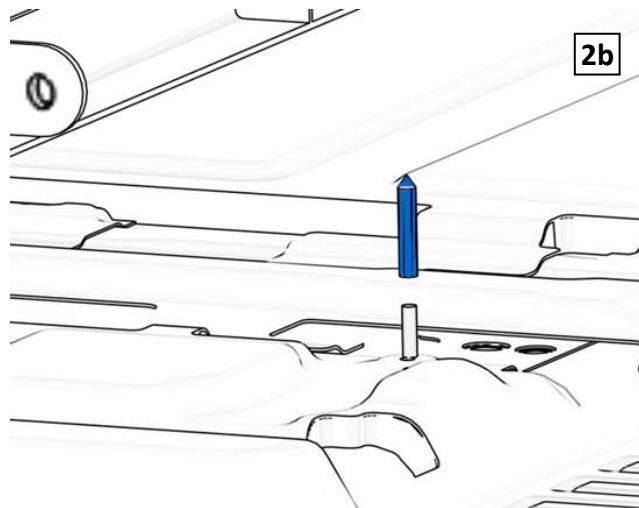

2c - Before setting seat in position, attach the seat edge trim (P451) to the seat as shown in the figure (attach edge trim to both driver and passenger sides).

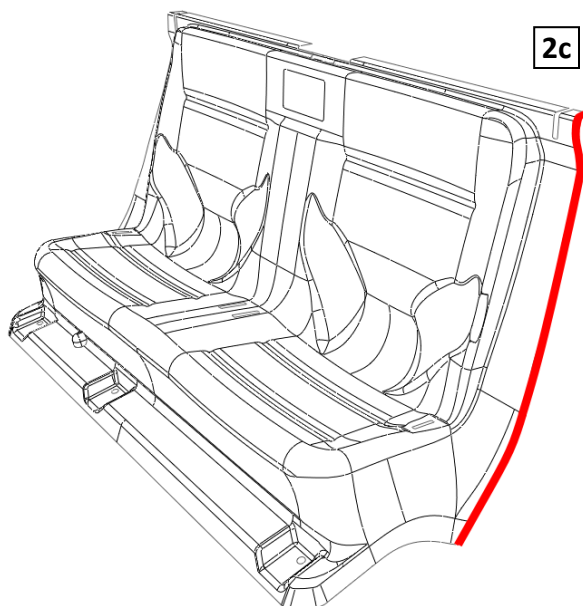

2d – Position the seat in place and pull the hip side tongues through the seat slots (both driver and passenger sides).

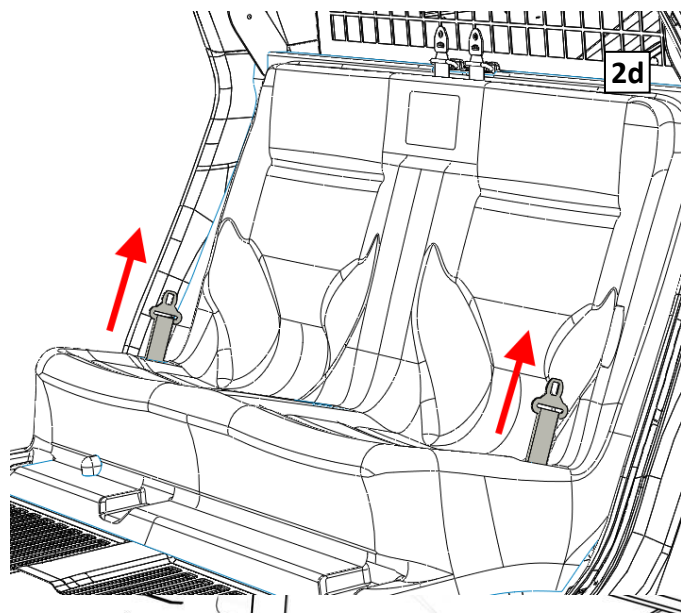

2e – From the back side of the assembly, find the end of the pre-installed retractors. Put them through the slots in the top of the seat and through the upper swivels as shown.

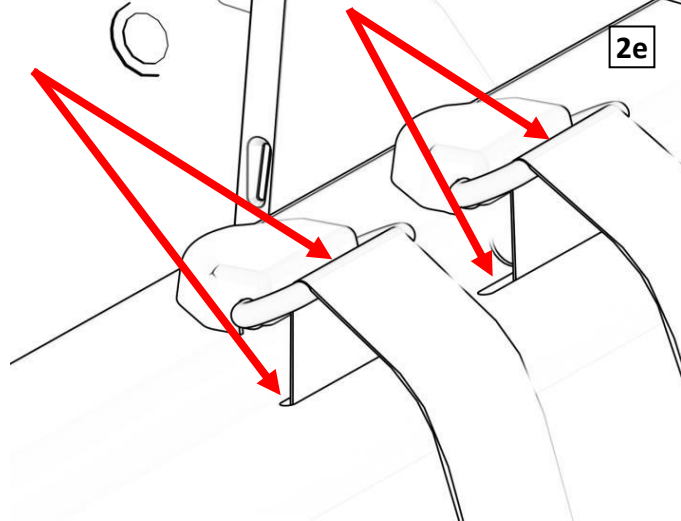

2f – Put the ends of the retractors through the sliding buckles (P002).

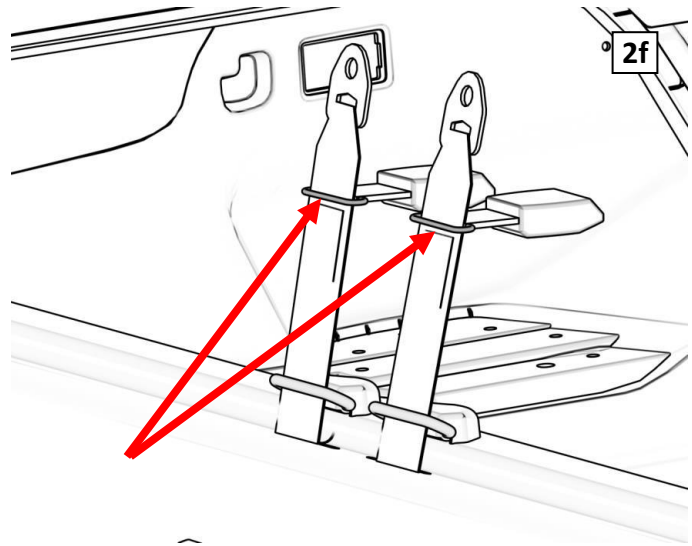

2g – Pull the ends of the retractors through the middle slots at the base of the seat and secure them using the provided 7/16-20 x 1"lg bolt (P216) and 7/16-20 hex nut (P160). Bolt the retractors to the previously install foot weldment bracket (PS-21TH-MNT-#fw).

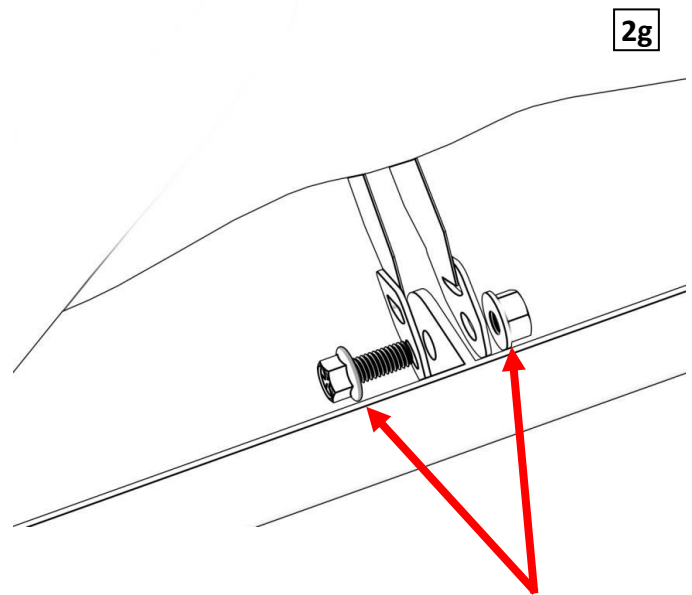

2h – At this point the installation should look like this image, bolt the lower front of the seat (P21T41) using the OEM hardware (x3).

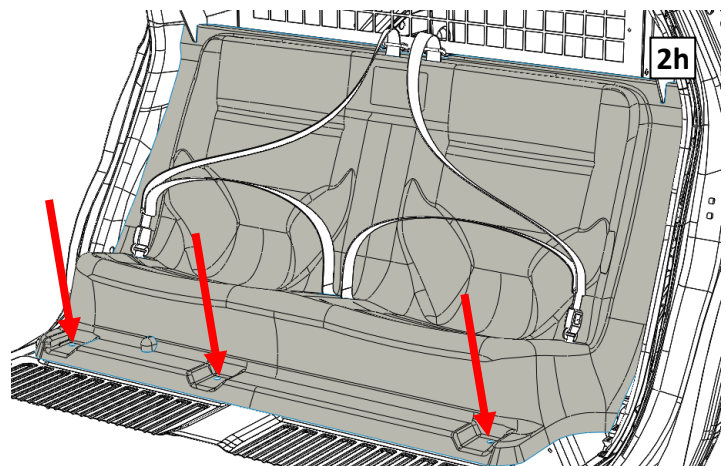

2i – Use the #14 x 1-½"lg self-drilling, self-tapping screws provided (P055) x2, drill through the seat to secure the seat against the top bar.

Note: 1 on each side.

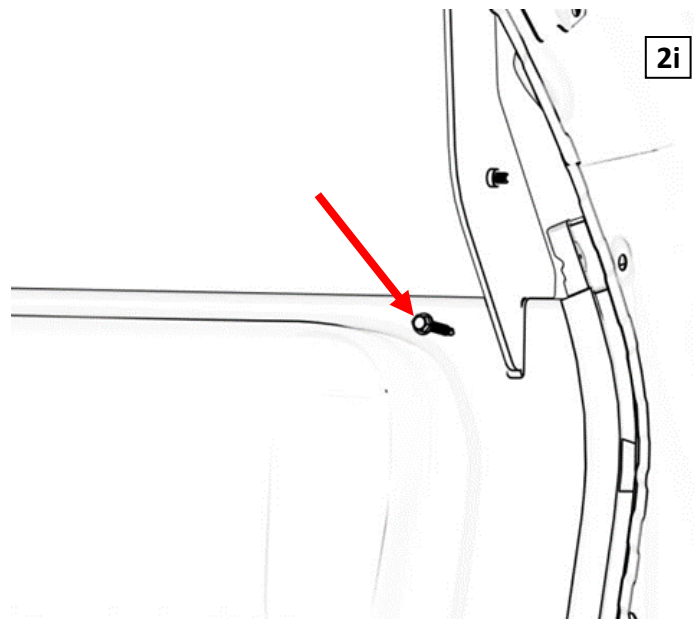

2j – Place the center belt slot covers (P005B) x2 around the previously installed seat belts and then pull the slot cover down and secure them into place over the slots in the seat using the #6 x 5/8" lg sheet metal screws (P057) x14.

Note: x7 screws per cover

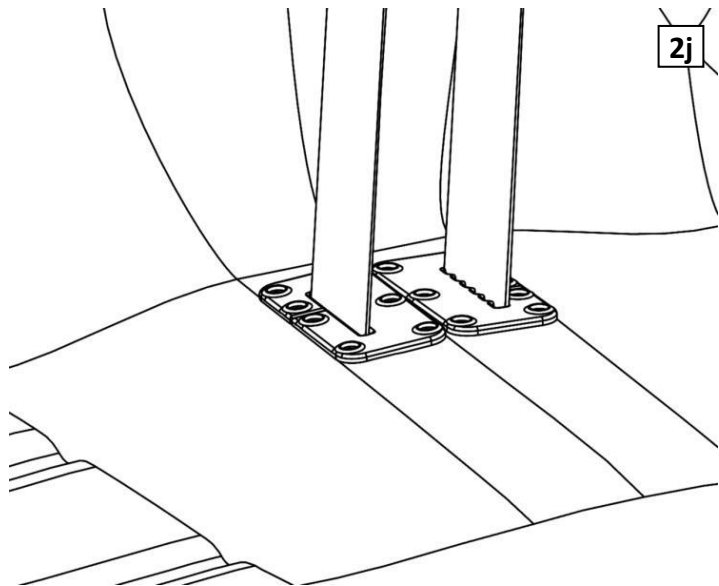

RP-21TH-#toptemp "PRINT TO "FIT TO PRINTABLE AREA""

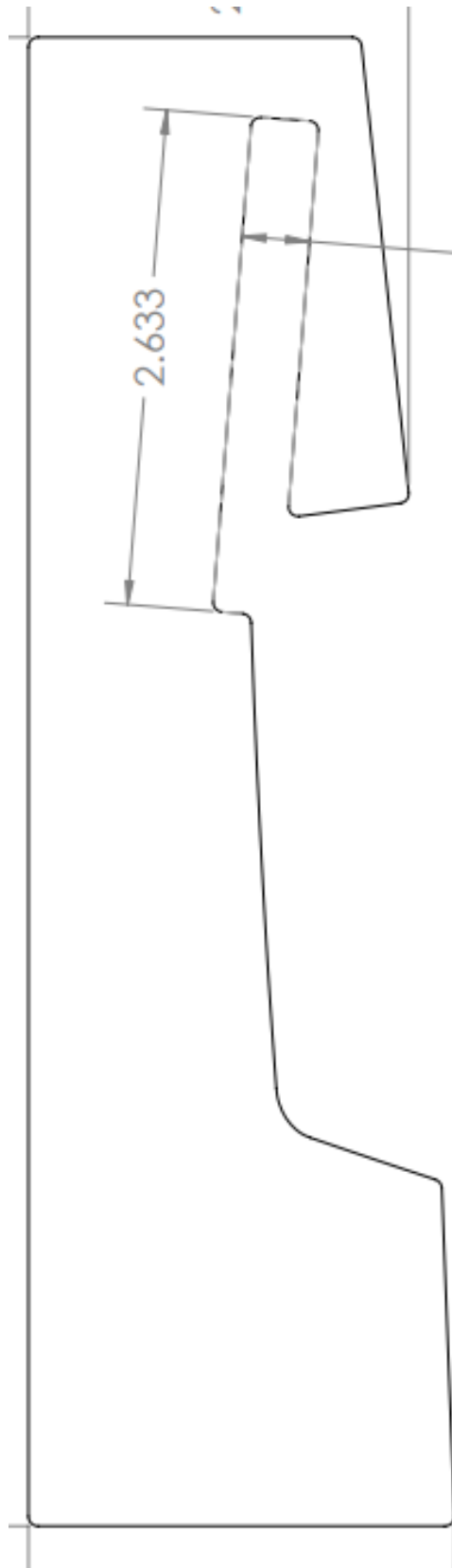

2k – Place the C-Toothed retainer(P004) around the seat belt (both sides) and secure with the provided #6 x 5/8"lg sheet metal screws (P057) x8.

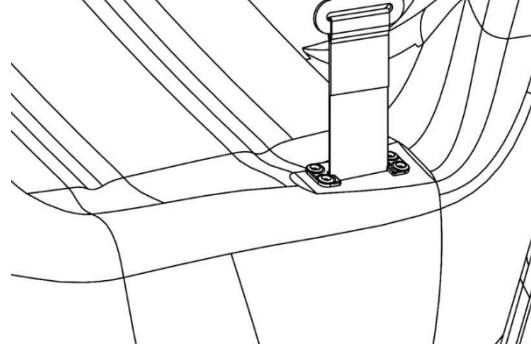

2h – Attach ear covers (P21T91-5D & P21T91-5P) using the provided $\frac{1}{4}$ "-20 x $\frac{3}{4}$ "lg button head screw (P059) x2.

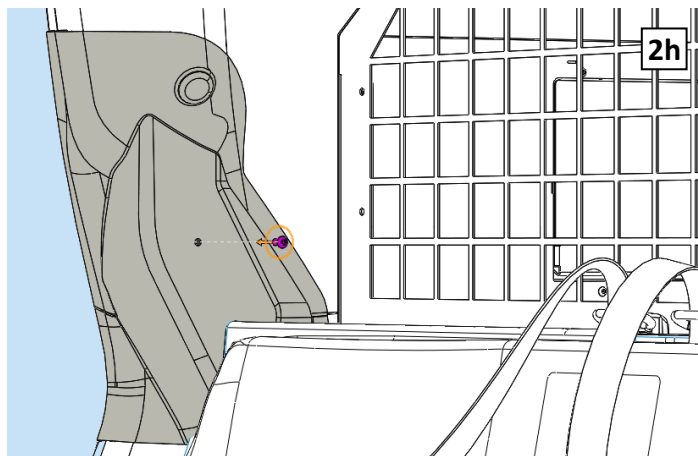

! **CAUTION** **!**

CHEMICAL CLEANERS will damage plastic seats and parts.

CLEAN ONLY with mild antibacterial soap and water.



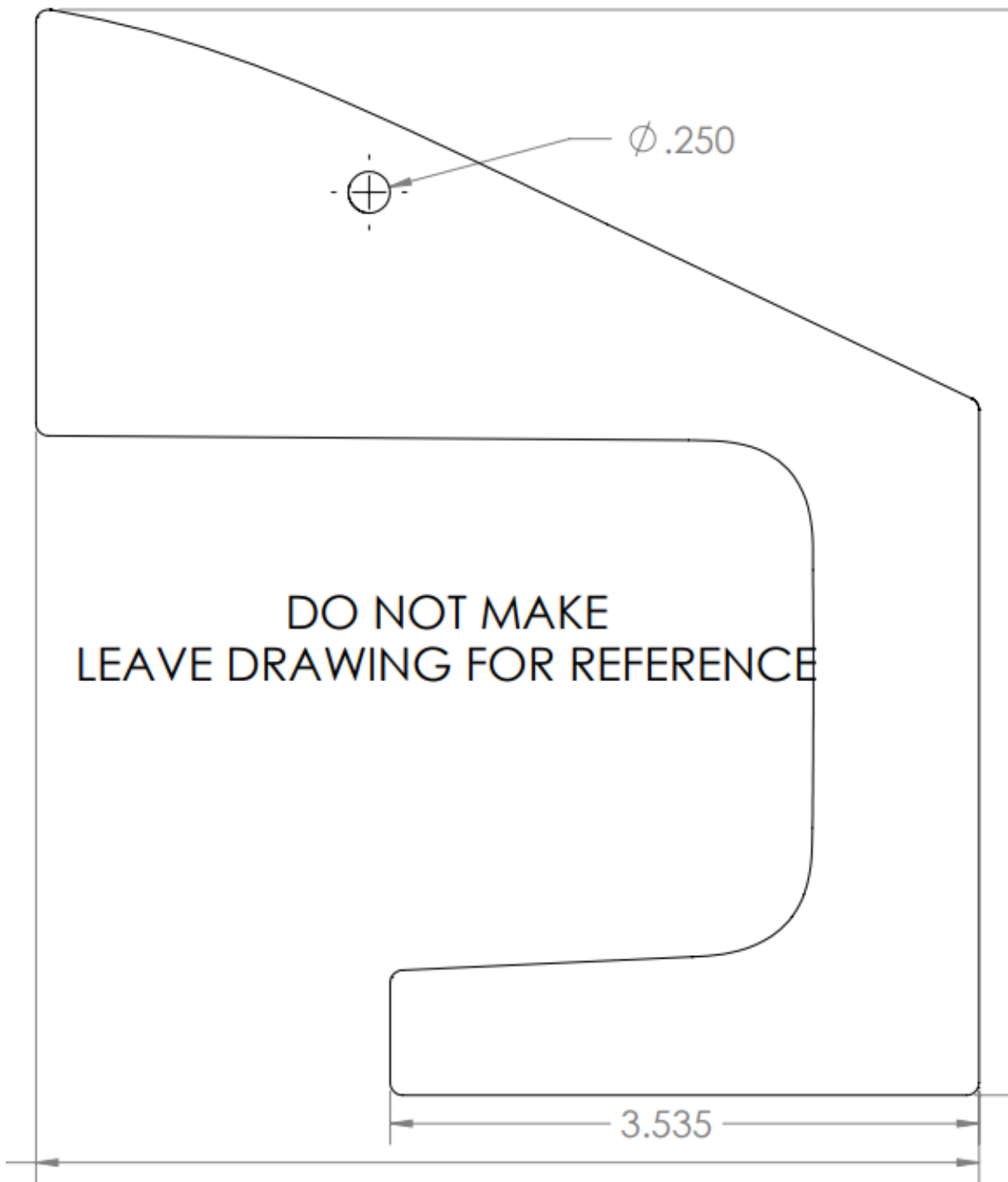

For any questions or feedback visit our website at prisonerseating.com or contact by phone at 775-453-4762

Your installation is now complete. If you have any questions or suggestions for adding additional instructions, please call **Customer Service at (800) 700-8769.**