



Dec 23, 2025

Revision D

A division of Troy Sheet Metal Works, Inc.
1024 South Vail Avenue, Montebello, CA 90640
www.troyproducts.com 323 720-4100

Part No: CP-21TH-CARGO
Description: Cargo Platform

Vehicle: Chevy Tahoe
Model year: 2021+

Tools Required:

Sockets
Swivel for Socket Wrench

Wrenches
Allen Keys

Extensions for Wrench
Drill + 1/8in bit

Troy Products recommends reading through all installation instructions prior to installation to check all necessary parts have been included (check against bill of materials table.)

IMPORTANT NOTE: Four gas shocks are included with the cargo mount. Use only two shocks (one per side) if **NO** box is to be installed on the cargo mount. If a box is to be installed, use all four shocks (two per side) to support the additional weight.

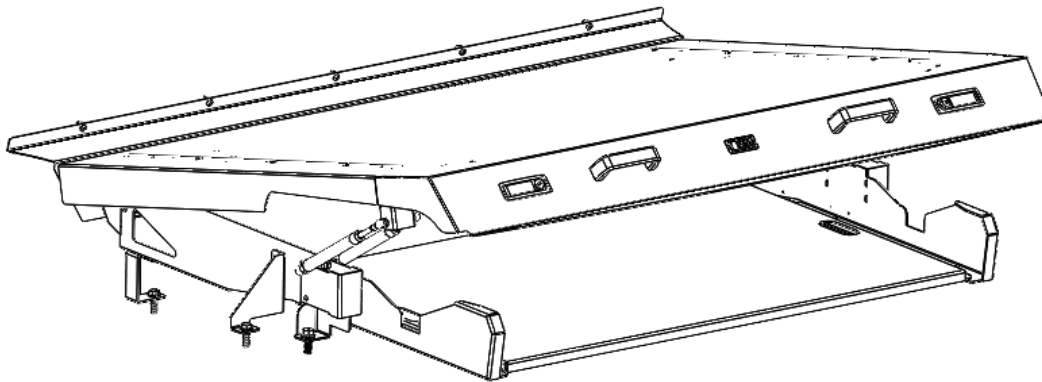





Quick Guide:

- 1.) Remove the 3rd row seats from the vehicle and prepare to make cutouts in the floor mat for the mounting brackets.
- 2.) Line up the side rails with the mounting brackets and install side rails.
- 3.) Once the side rails are in place the cross bar, gap panel, and electronics tray can be installed.
- 4.) Install the appropriated number of gas shocks, see **STEP 8** for details.
- 5.) Finally, the lid assembly can be installed and locks on the lid can be adjusted.

CP-21TH-CARGO - BILL OF MATERIALS

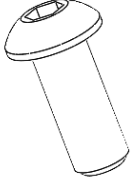
PARTS	
<p>Part number: CP-21TH-CARGO-#gap</p> <p>Description: GAP PANEL</p> <p>QTY: 1</p>	<p>Part number: CP-21TH-CARGO-#xt</p> <p>Description: CROSS SUPPORT</p> <p>QTY: 1</p>
<p>Part number: CP-21TH-CARGO-#ppa</p> <p>Description: PASSENGER PIVOT ASSEMBLY</p> <p>QTY: 1</p>	<p>Part number: CP-21TH-CARGO-#dpa</p> <p>Description: DRIVER PIVOT ASSEMBLY</p> <p>QTY: 1</p>
<p>Part number: CP-21TH-CARGO-#la</p> <p>Description: LID ASSEMBLY</p> <p>QTY: 1</p>	<p>Part number: CP-21TH-CARGO-#lfp</p> <p>Description: LEG, FORWARD, PASSENGER</p> <p>QTY: 1</p>
<p>Part number: CP-21TH-CARGO-#lfd</p> <p>Description: LEG, FORWARD, DRIVER</p> <p>QTY: 1</p>	<p>Part number: CP-21TH-CARGO-#net</p> <p>Description: ELECTRONICS TRAY</p> <p>QTY: 1</p>

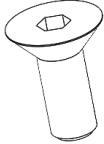
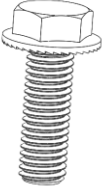
HARDWARE

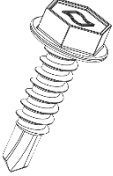
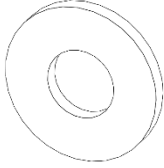
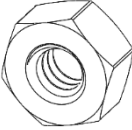
<p>Part number: 1-FST-06-60825</p> <p>Description: ¼-20 x 5/8 BH SOCKET SCREW</p> <p>QTY: 14</p>		<p>Part number: 1-FST-35-31000</p> <p>Description: 1/4-20 NYLON NUT</p> <p>QTY: 14</p>	
<p>Part number: 1-FST-04-65620</p> <p>Description: 10-32 x ½ FH SOCKET SCREW</p> <p>QTY: 8</p>		<p>Part number: 1-FST-09-M1030</p> <p>Description: M10-1.5 x 30mm FLANGE HEAD</p> <p>QTY: 4</p>	
<p>Part number: 1-FST-10-66321</p> <p>Description: 7/16-20 x 1.125 TRI-LOBE FLANGE BOLT</p> <p>QTY: 2</p>		<p>Part number: 1-FST-58-4A785</p> <p>Description: #10 x 3/4 " SELF DRILLING SCREW BLK</p> <p>QTY: 5</p>	
<p>Part number: 1-FST-50-11208</p> <p>Description: 3/8 WASHER BLK</p> <p>QTY: 2</p>		<p>Part number: 1-FST-33-10800</p> <p>Description: ¼-20 HEX NUT</p> <p>QTY: 4</p>	

Installation

- 1.) Remove the 3rd row seats from the vehicle to expose the floor trim as shown below.

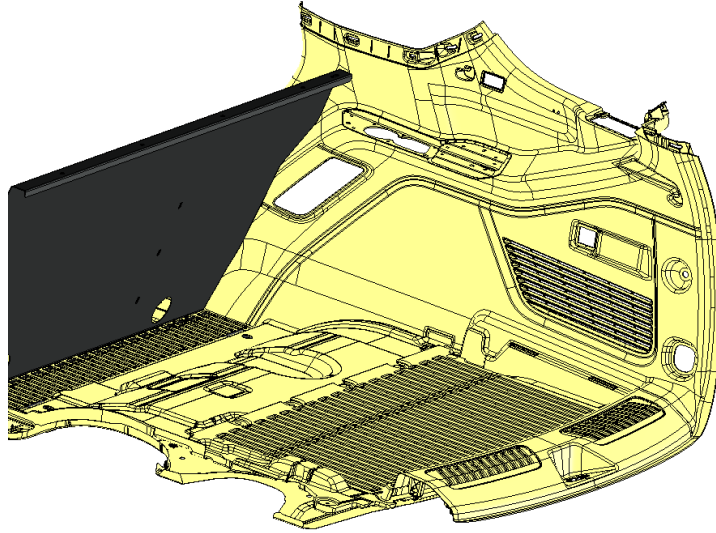

- 2.) Install the forward leg mounting brackets loosely into the forward part of the vehicle and on top of the rear partition cover mounting brackets if using a Troy rear partition. Rubber mats will need to be cut. **DO NOT FULLY TIGHTEN AT THIS TIME**

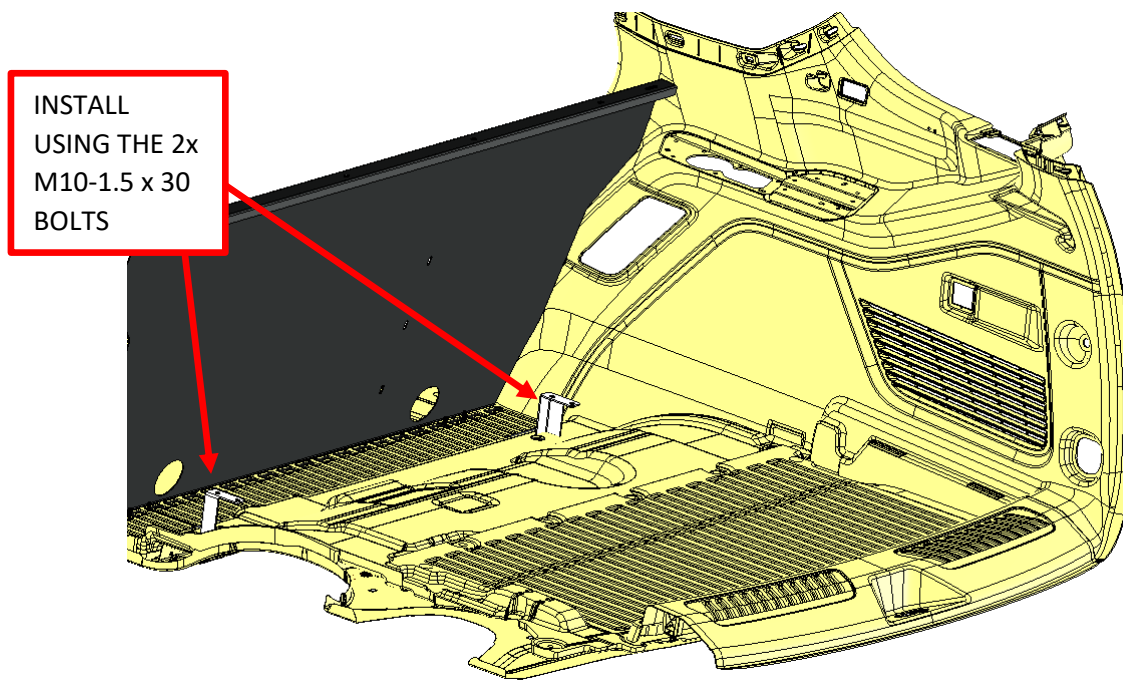

INSTALL
USING THE 2x
M10-1.5 x 30
BOLTS



CUT A CROSS SHAPE INTO THE
RUBBER MAT TO REACH BOLT HOLES

- 3.) Cutouts will need to be made in the floor mat to allow for the four mounting points towards the back of the vehicle to sit on the metal structure of the vehicle. Washers will be placed under the side rails on the passenger side to level the assembly left to right. Floor mats can be removed from vehicle if desired.

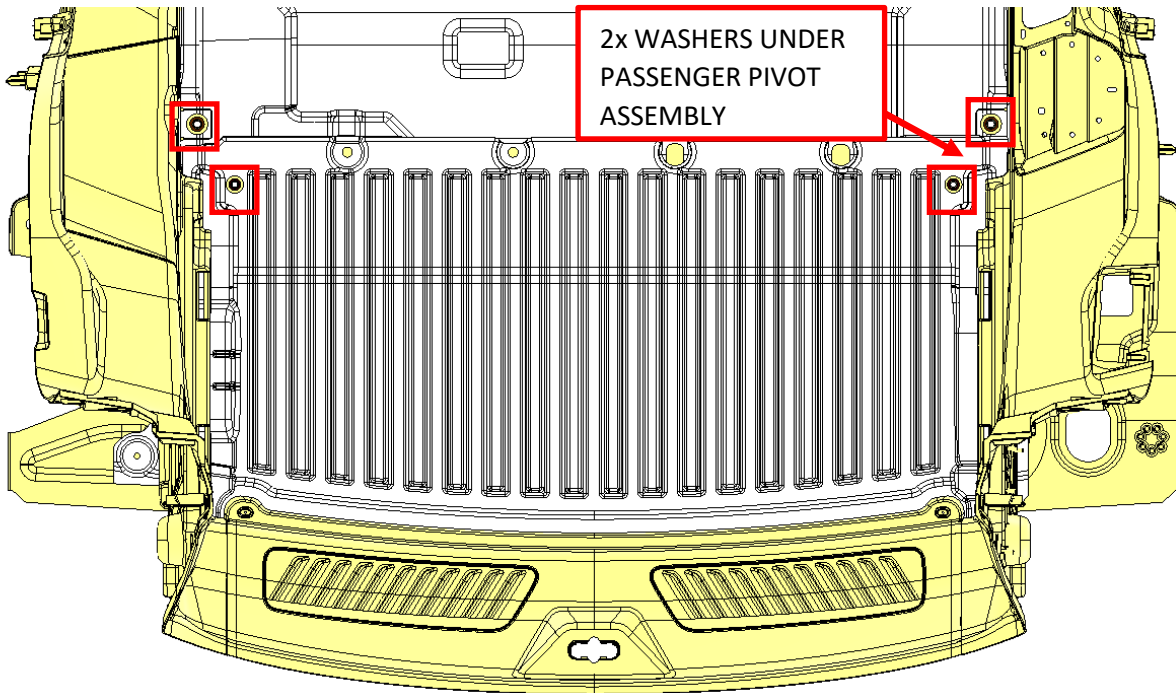

- 4.) Install the pivot assembly on both sides of the cargo area as shown below. **DO NOT FULLY TIGHTEN AT THIS TIME**

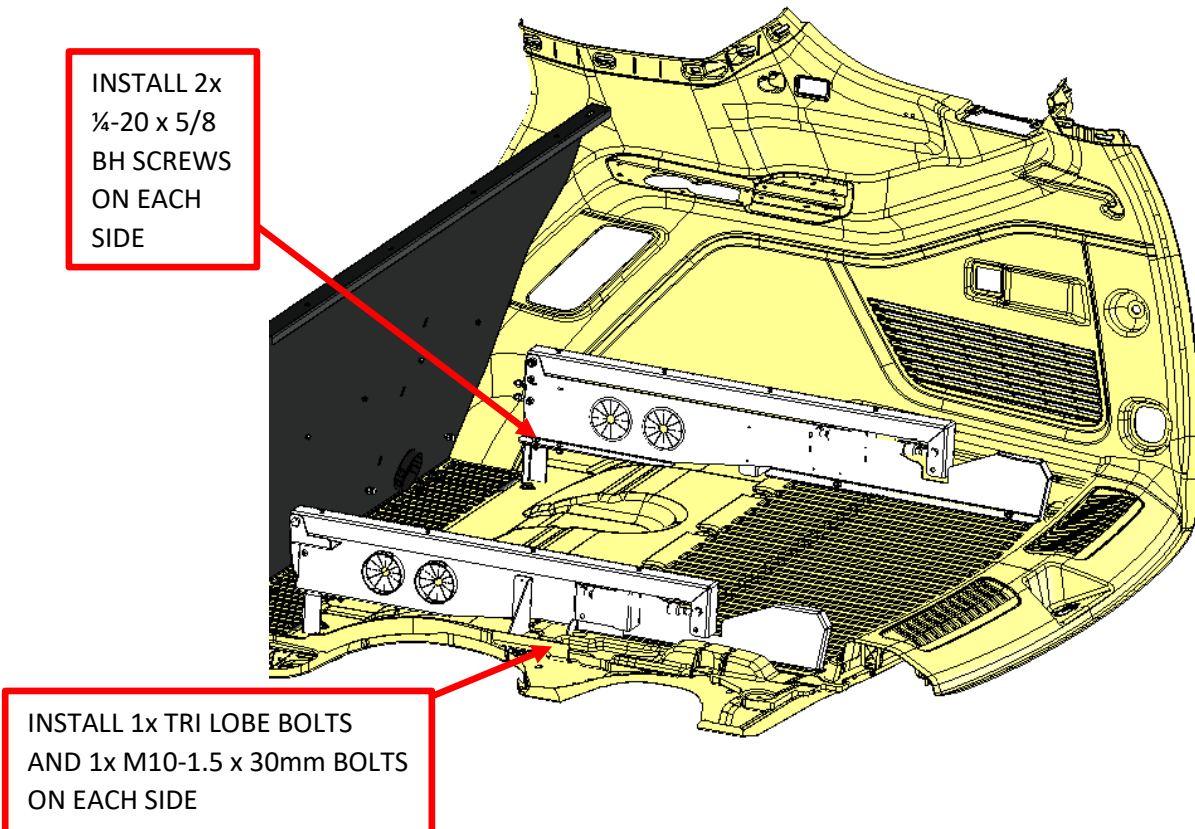

- 5.) The cross support will need to be installed next, after installing cross support all currently installed hardware will need to be fully tightened. **FULLY TIGHTEN HGDWARE AT THIS TIME**

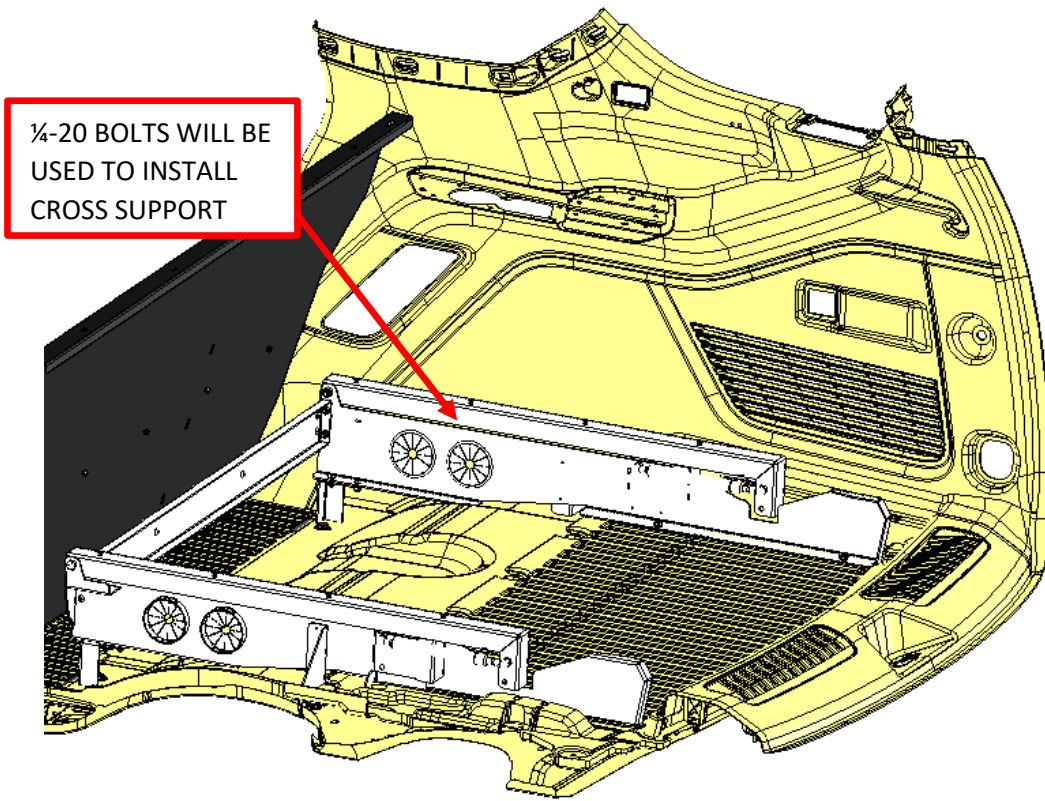

- 6.) The gap panel will need to be installed next, for this step you will need to carefully slide the gap panel between the rear partition and attach it to the cross support using 6x 1/4-20 bolts and 6x 1/4-20 nylock nuts. A drill with a 1/8 bit is needed in order to drill 5x pilot holes for the #14 sheet metal screws that will attach to the rear partition cargo cover. **FULLY TIGHTEN**

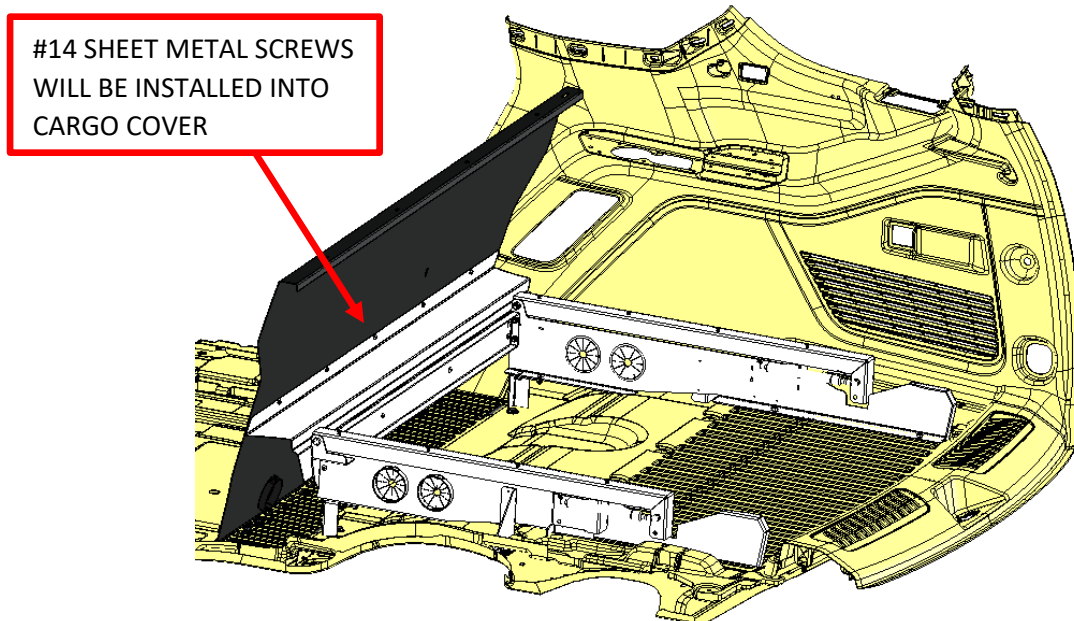

- 7.) The electronics tray slides onto the four pem studs and will be installed at this time using 4x nuts to secure it to the cargo area as shown below.

FULLY TIGHTEN AT THIS TIME

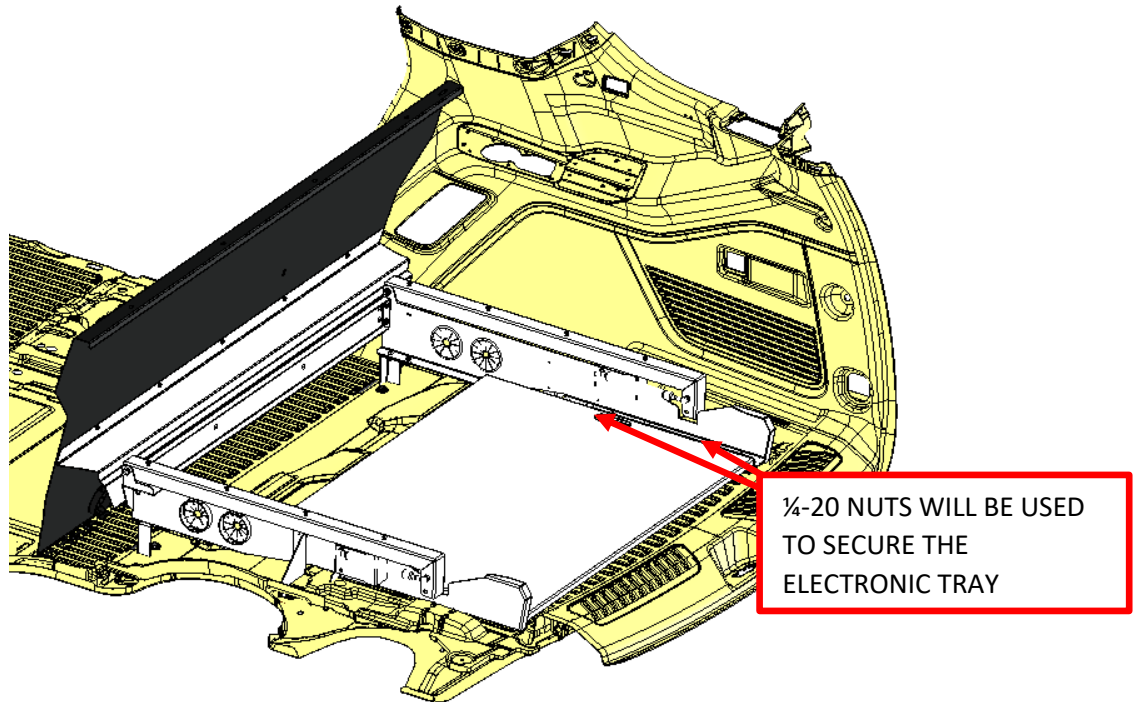

- 8.) Four gas shocks are included with the cargo mount. **Use two shocks (one per side) if NO box is to be installed on the cargo mount. If a box is to be installed, use all four shocks (two per side) to support the additional weight.**

Install the ball studs along with the 5/16" nylon lock nuts on the base and rail brackets using two 1/2" open-end wrenches, then snap the gas shocks onto the installed ball studs.

Ball studs installation

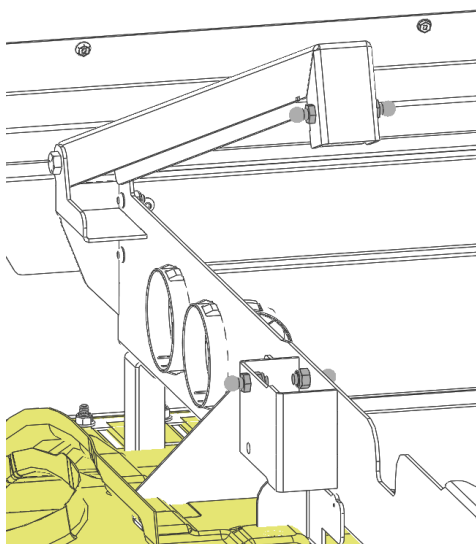

Install the appropriated number of gas shocks

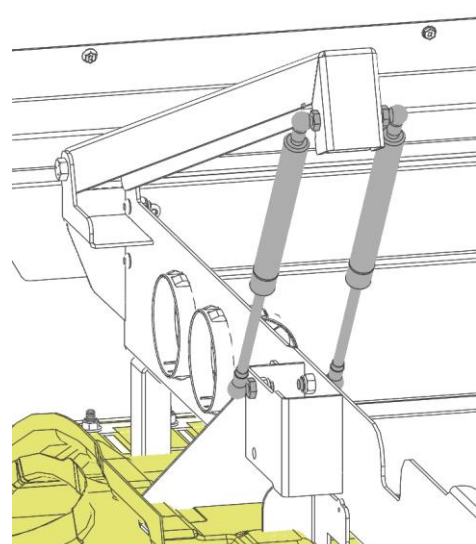

9.) The lid will now be carefully placed on the rails, cardboard can be placed on the sides of the vehicle to protect plastic trim when installing the lid. Fasten to the pivot assemblies with the included #10-32 FH screws. **FULLY TIGHTEN**

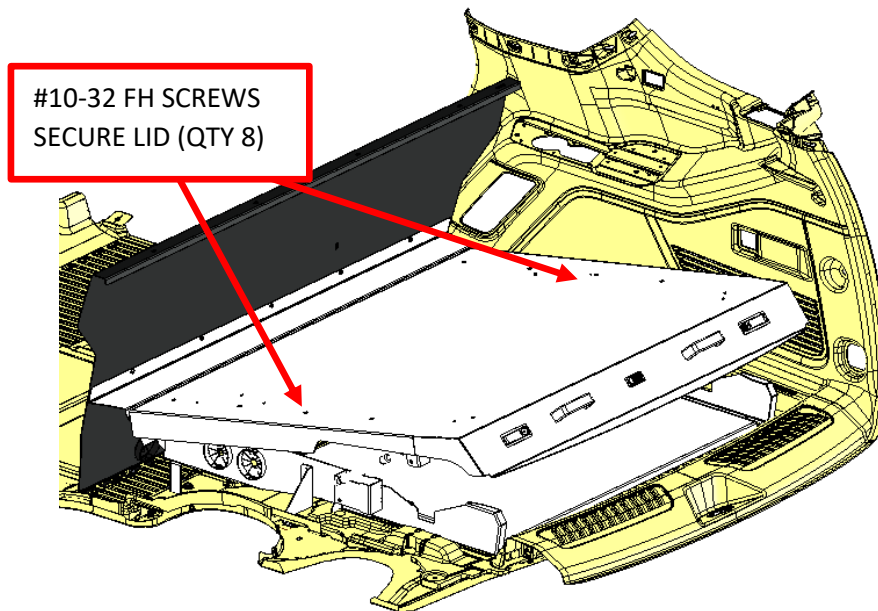

Your installation is now complete. If you have any questions or suggestions for adding additional instructions, please call **Customer Service at (800) 700-8769.**